



Natural Resources Conservation Service

A photograph of a rural landscape featuring a pond in the foreground, surrounded by tall grasses and trees. In the background, there are rolling hills and a few buildings, including a white silo. The sky is clear and blue.

SITES Software NHCP-378 Pond w/ pipe

Karl Visser, PE, NDCSMC
Hydraulic Engineer

Phuc Vu, PE, CNTSC
Agricultural Engineer
Ft Worth, TX

Overview

Design scenario -

- NHCP standard 378 – Pond
- Principal Spillway through embankment
- Auxiliary Spillway

SITES Objectives -

- SITES input screens
- SITES output
- SITES project directories and files



Natural Resources Conservation Service

A photograph of a rural landscape. In the foreground, there is a pond surrounded by tall, dry grasses. The pond reflects the surrounding trees and sky. In the background, there are rolling green hills, a few farm buildings, and a line of trees under a clear sky.

NHCP standard 378 – Pond

NHCP 378 - Pond

Where do I find design requirements for a pond?

- eFOTG Section IV for your state/county

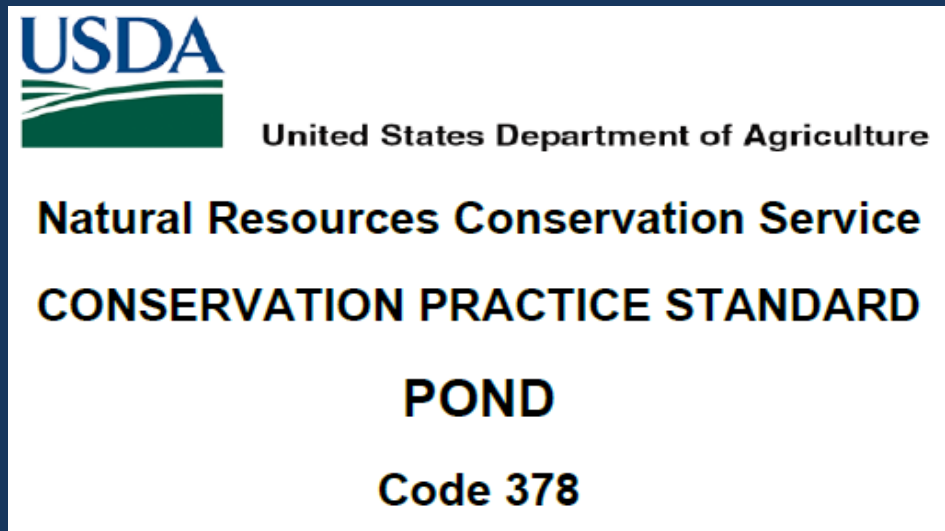

Pond – 378 Limits (national)

	378 - POND	402 – DAM TR-60
Eff Ht	< 35 ft*	
Sto x Ht	< 3,000 ac-ft²*	Everything else
Hazard	Low*	

*Must meet all 3 criteria

Pond Effective Height: < 35 ft

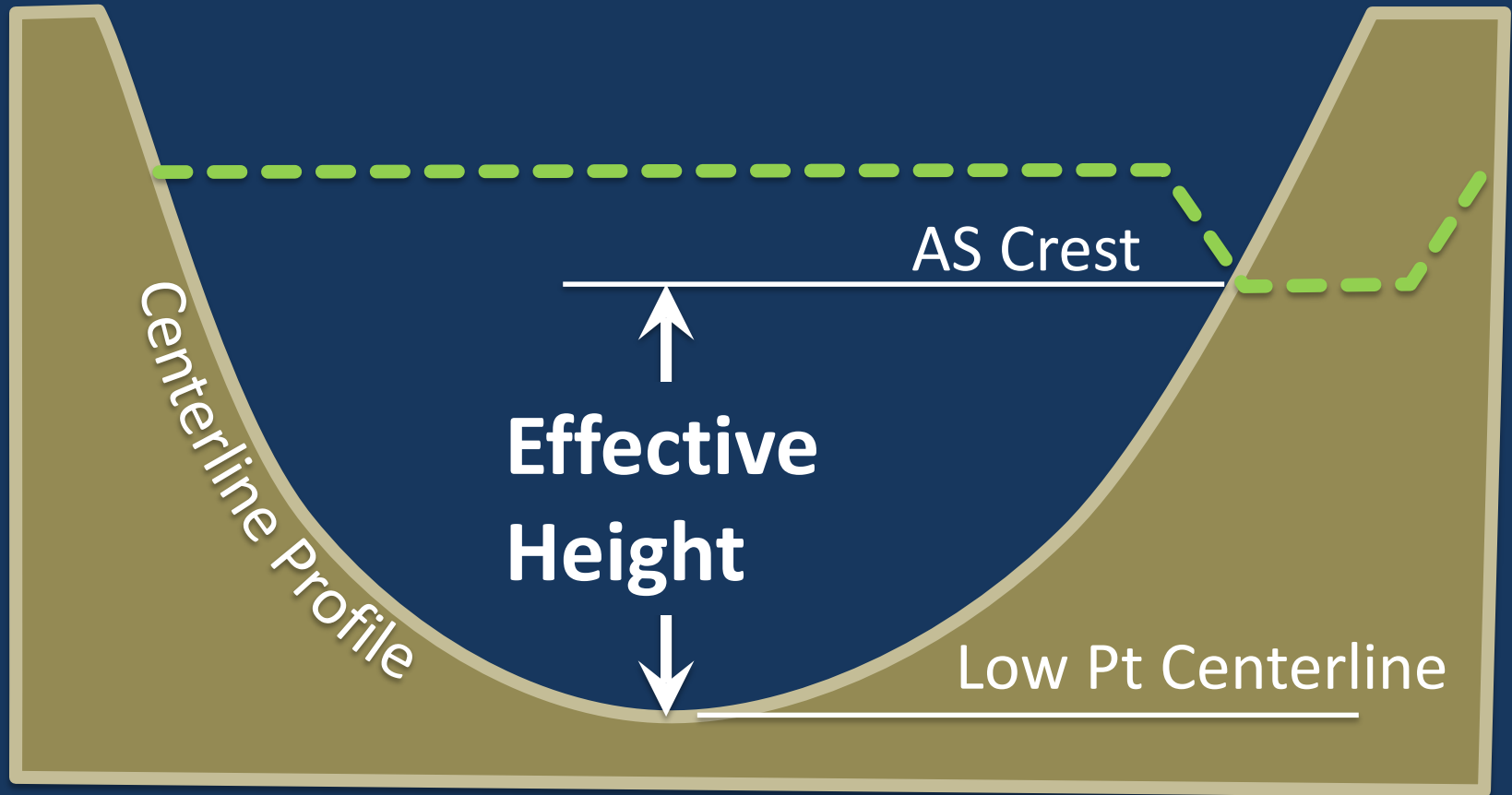

What Design Storm for Aux Spwy?

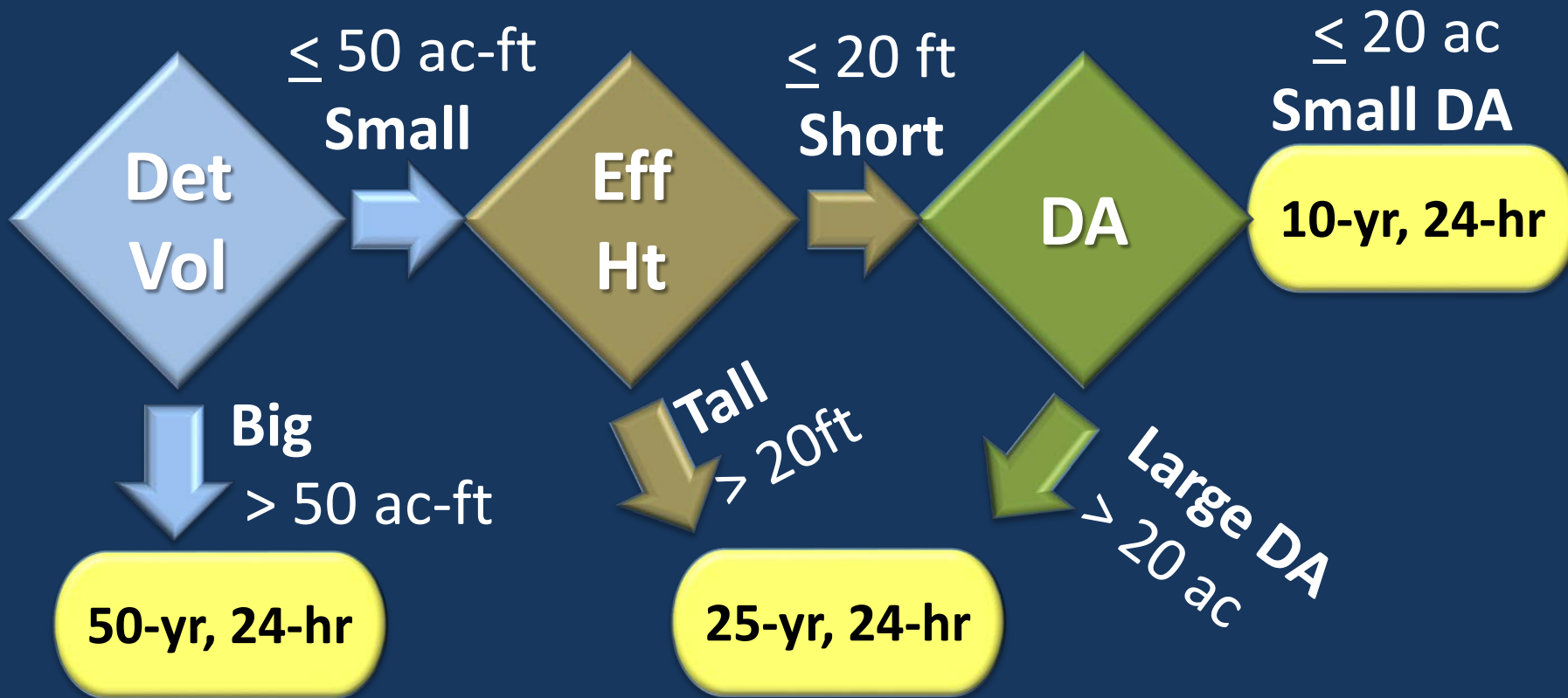
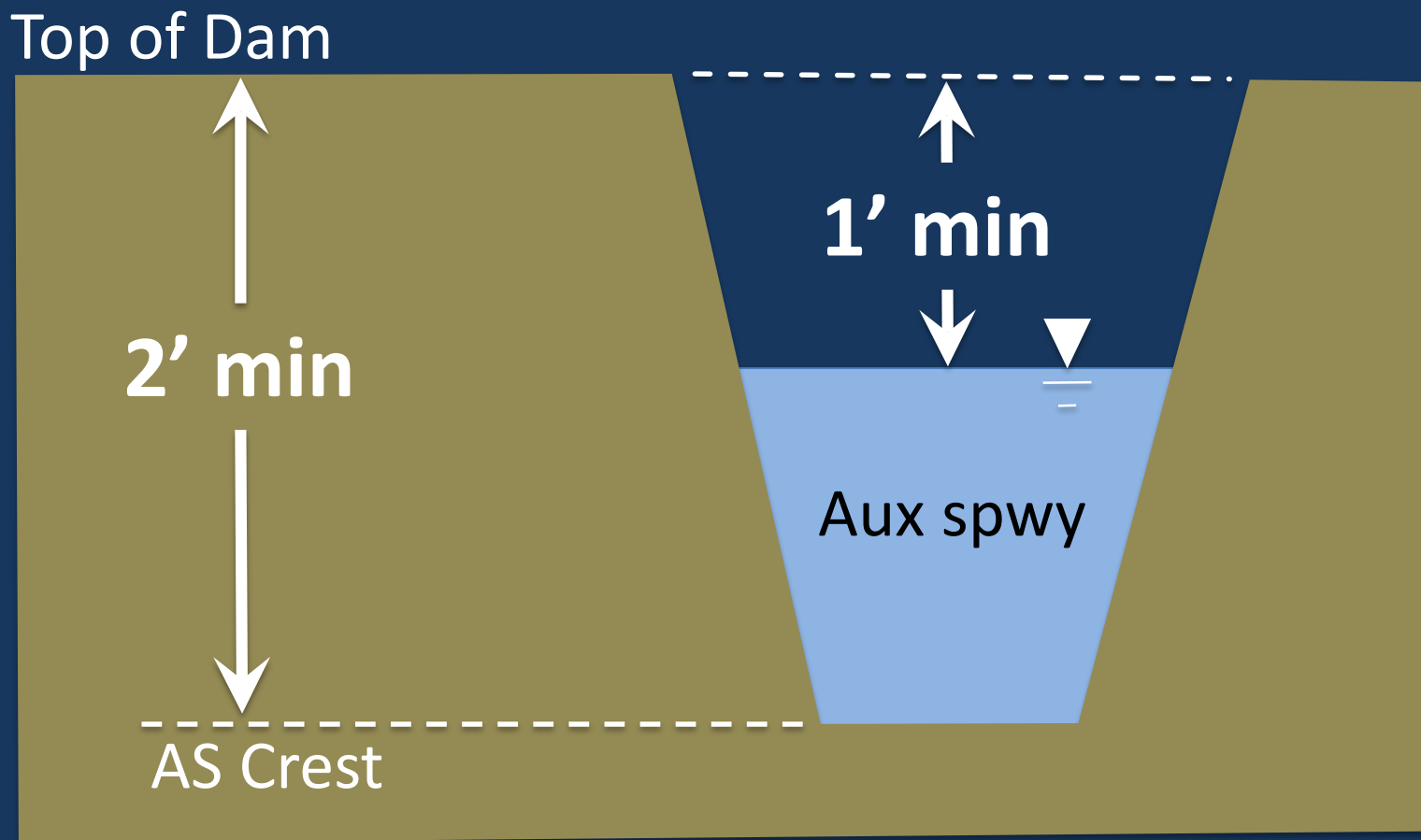

Table 2. Minimum auxiliary spillway capacity

Freeboard – auxiliary spillway



SITES Input Interface

SITES Software

378 – Pond Example

Karl Visser
&
Tony Funderburk (ret)

2005.1

Water Resources Site Analysis Program

Agricultural Research Service NRCS Natural Resources Conservation Service Kansas State University

SITES Software

- Current version is 2005.1.8
- CCE-certified
- Is SITES an acronym?

Stability & Integrity Technology for
Earth Spillways



Natural Resources Conservation Service

SITES input screens

How do I input information for my
pond into SITES?

Data Entry Sections

- Global Options
- Watershed
- Storage Volume
- Rainfall
- Inlet (pipe & riser)
- Embankment Volume (optional)
- Auxiliary spillway

SITES Input Interface

Start →

All Programs →

Engineering Applications →

SITES 2005.1.8

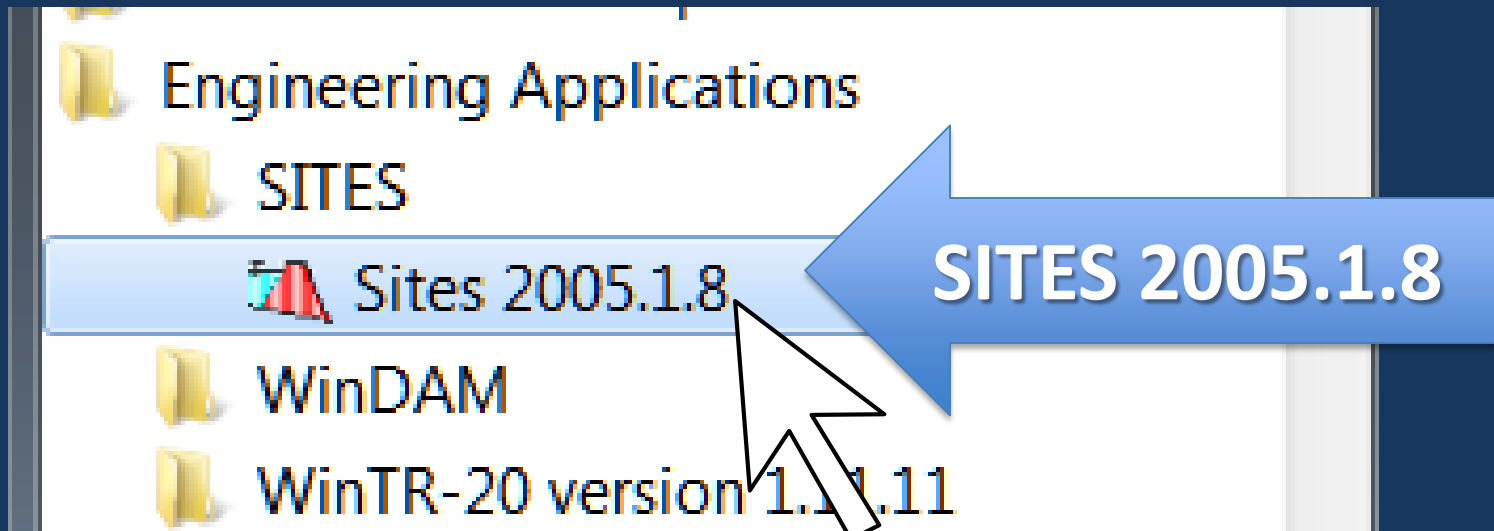



Natural Resources Conservation Service

Global Options

Global Watershd Data

Global Watershed Data ✕

WATERSHED ID

TITLE

HYDROLOGIC DATA ENTRY OPTIONS

NRCS (TR-60)

NRCS (NHCP-378)

Principal Spillway

378 Design

Secondary Design

SINGLE EVENT

SPECIAL AUXILIARY SPILLWAY ANALYSIS (SINGLE SPILLWAY)

- **NHCP-378**
- **Principal Spwy**
- **378 Design**

Blank Schematic

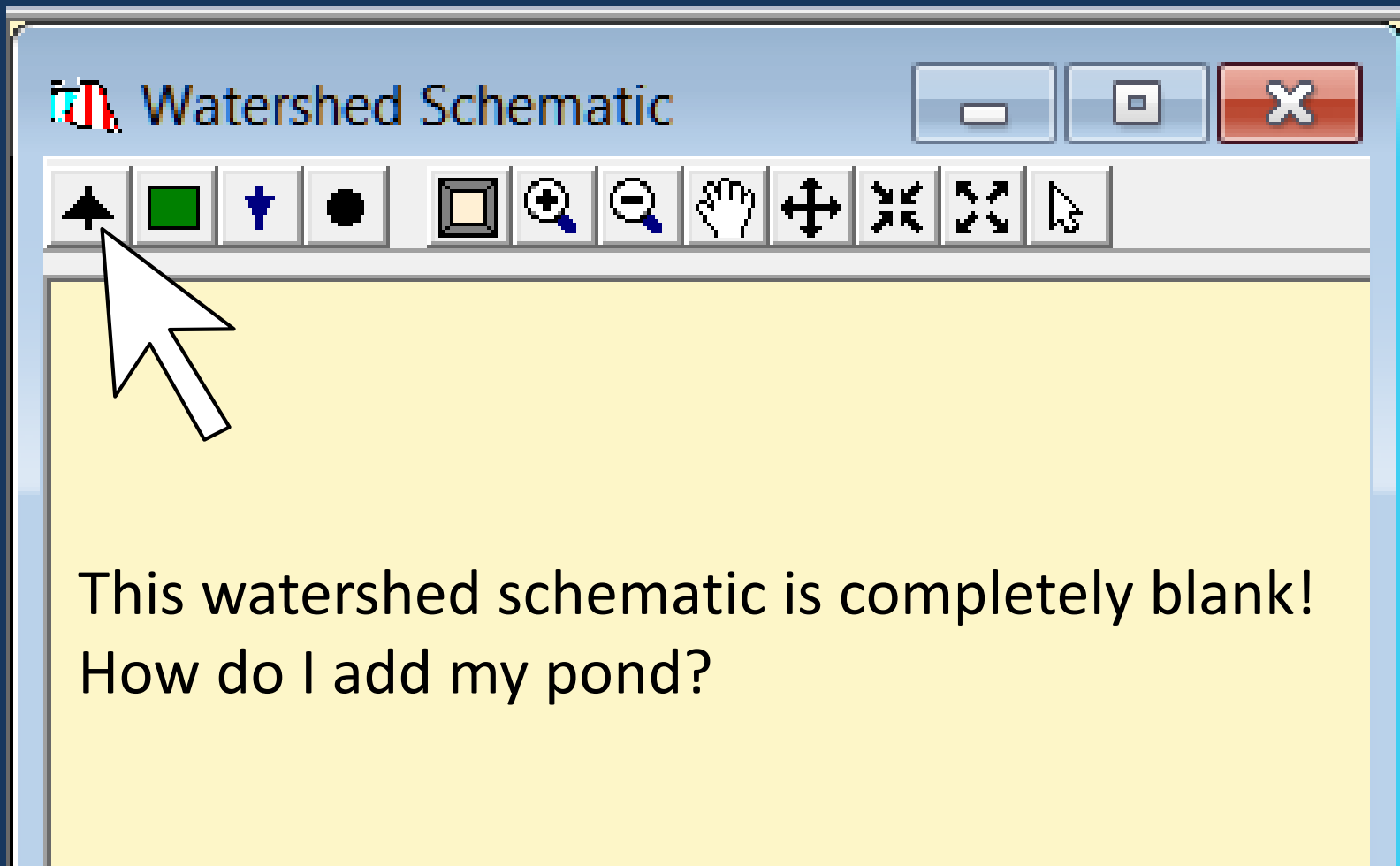

This watershed schematic is completely blank!
How do I add my pond?

Pond Added to Schematic

The screenshot shows a software window titled "Watershed Schematic". The toolbar contains several icons: a tree, a green square, a blue plus sign, a black circle, a square with a smaller square inside, a magnifying glass with a plus sign, a magnifying glass with a minus sign, a hand, a four-way arrow, a four-way arrow with dots, a four-way arrow with squares, and a mouse cursor. A bracket groups the zoom, pan, and select tools. The schematic area has a vertical legend with "Pond" (tree icon), "Watershed" (green square), "Reach" (blue plus), and "Jct" (black circle). A mouse cursor is hovering over a tree icon in the schematic area.

Zoom/Pan/Select tools

Dbl-click pond icon to enter pond info

Watershed Info

Watershed Information
X

Sub-Watershed ID:

Design Class: Low Hazard (A1)

Drainage Area:

Square Miles

Acres

DA: 50 acres

Comments

DEM01-Livestock Water

Location; Lamar County, TX, 0.7 mile SW of Chicota, TX

PSH-5yr-24hr=5.5 inches-TYPE III

FBH-25yr-24hr=7.8 inches-TYPE III

Auxiliary Spillway-Allowable Velocity=3.5 fps.

} comments

Hydrologic Data Options

Enter Rainfall



Natural Resources Conservation Service

Storage Volume

How much water can this pond store?

Storage

- Elevation vs surface area
(*acres*)

OR

- Elevation vs volume
(*acre-feet*)



Structure Data Tbl

Structure Data Table

Structure ID:

Title:

	Elevation	Area		Volume
	Elevation (Feet)	Surface Area (Acres)	PS Discharge (CFS)	Storage Vol. (Acre Feet)
1	90	0.00		
2	96.0	1.2		
3	97.0	1.6		
4	98.0	2		
5	99.0	4		
6	100.0	5.4		
7	101.0	7.0		
8	102.0	9		
9				



Natural Resources Conservation Service

Watershed

What is the pond's drainage area?

Watershed

- Drainage area (acre or sq mi)
- Runoff Curve Number
- Time of concentration (hr)

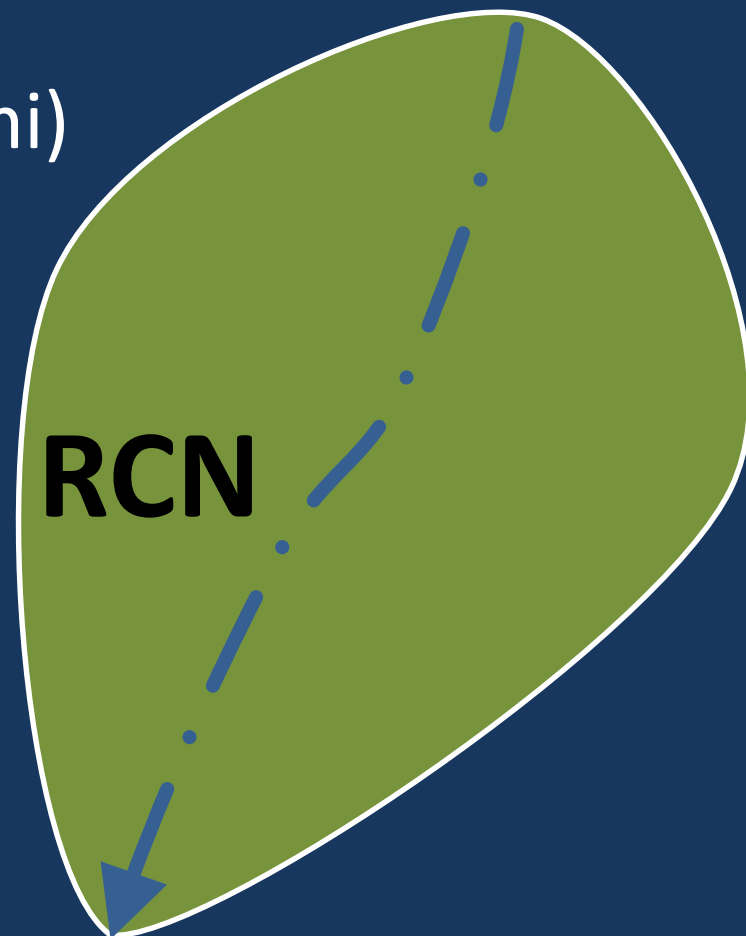

Watershed Data

Watershed Data
X

(t_c) or (WS length & WS slope)

2,000 ft 2%

Time of Concentration, Hours:

WS Length, Ft. WS Slope, %:

Curve Number: Base Flow, CSM:

RCN: 71



Natural Resources Conservation Service

Rainfall

How much design rainfall?

Rainfall Data: PS

The screenshot shows a software window titled "Rainfall Data" with two tabs: "Principal Spillway" (selected) and "Auxiliary Spillway". The main display area shows "5-yr PS rainfall: 5.5 inches" and "378 One Day Rainfall: 5.5 In.". A radio button labeled "Point Rainfall" is selected. A yellow callout box at the bottom of the window contains the text "Max WSE sets AS crest".

Rainfall Data: Aux Spwy

Rainfall Data
✕

Principal Spillway
Auxiliary Spillway

378 Design Rainfall:

**AS rainfall: 7.8 inches
25-yr**

**Max WSE sets
top of dam
elev**

Rainfall distribution: 24-hr Type III

Standard Distribution:

NRCS 24 hr Type III

NRCS 6 hr
 NRCS 24 hr Type I
 NRCS 24 hr Type I A
 NRCS 24 hr Type II
 NRCS 24 hr Type III

Raintable
 Use the rainfall appropriate Hy watershed.

Pool Data

Pool Data
X

Generally set sed. pool & perm. pool
 @ crest of riser

Flood Pool Sediment:

96.0

96.0 ft

Units

- Elevation, Feet
- Inches
- Acre Feet

Permanent Pool:

96.0

96.0 ft

Natural Resources Conservation Service



Inlet: Riser & Pipe

Riser crest
Elev 96.0'

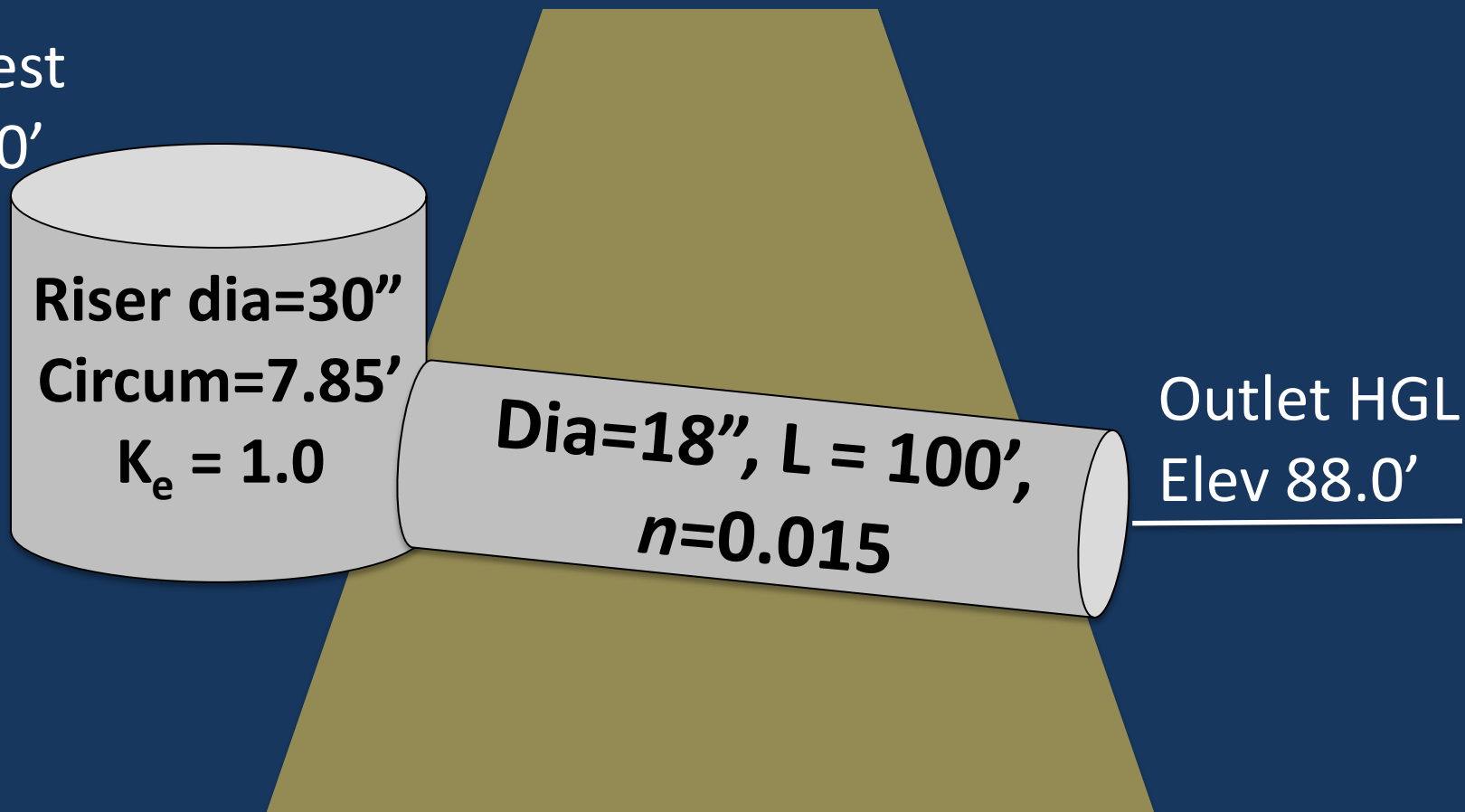

PS Type

Principal Spillway Type
X



Single Stage Inlet, Circular Conduit



Single Stage Inlet, Rectangular Conduit



Hood Inlet, Circular Conduit

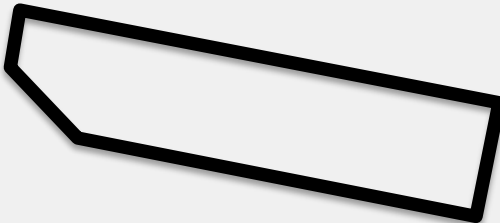

PS: Inlet tab

Principal Spillway: Single Stage Inlet, Circular Conduit

Inlet Inlet Conduit

Principal Spillway Crest, Elev.:	<input type="text" value="96.0"/>	96.0 ft
Weir Length, Feet:	<input type="text" value="7.85"/>	7.85 ft
Entrance Loss Coefficient, Ke:	<input type="text" value="1.0"/>	1.0

PS: Conduit tab

Principal Spillway: Single Stage Inlet, Circular Conduit

Conduit

Inlet	Conduit
Number of Conduits:	<input type="text" value="1"/> 1
Length of Conduits, Feet:	<input type="text" value="100"/> 100 ft
Diameter of Conduits, Inches:	<input type="text" value="18"/> 18 in
Manning's "n" Value:	<input type="text" value=".015"/> 0.015
Elevation, HGL at Outlet, Feet:	<input type="text" value="88."/> 88.0 ft

Natural Resources Conservation Service

Embankment Volume (optional)



Valley Elevations

Valley Elevations
X

Elevation of Valley Floor, Feet:

Valley Floor Elevation: 86.5 ft

Low Point on Embankment Centerline:

Profile along Embankment Centerline

Surveyed Centerline X-Section

Station	Elevation
0+00	102.6
0+40	100.2
0+70	99.7
1+20	98.0
1+40	96.2
1+50	94.3
1+75	93.4
2+50	87.1
3+00	91.5
3+50	100.0
4+00	102.7

Profile: Valley X-Sect

 Profile: Valley X-Sect
X

Elevation Adjustment Factor (ft):

Title:

	1	2	3	4	5	
Dist. Ft.	0	40	120	140	250	
Elev., Ft.	103	100.	98.0	96.	87.	

◀

▶

Embankment Section

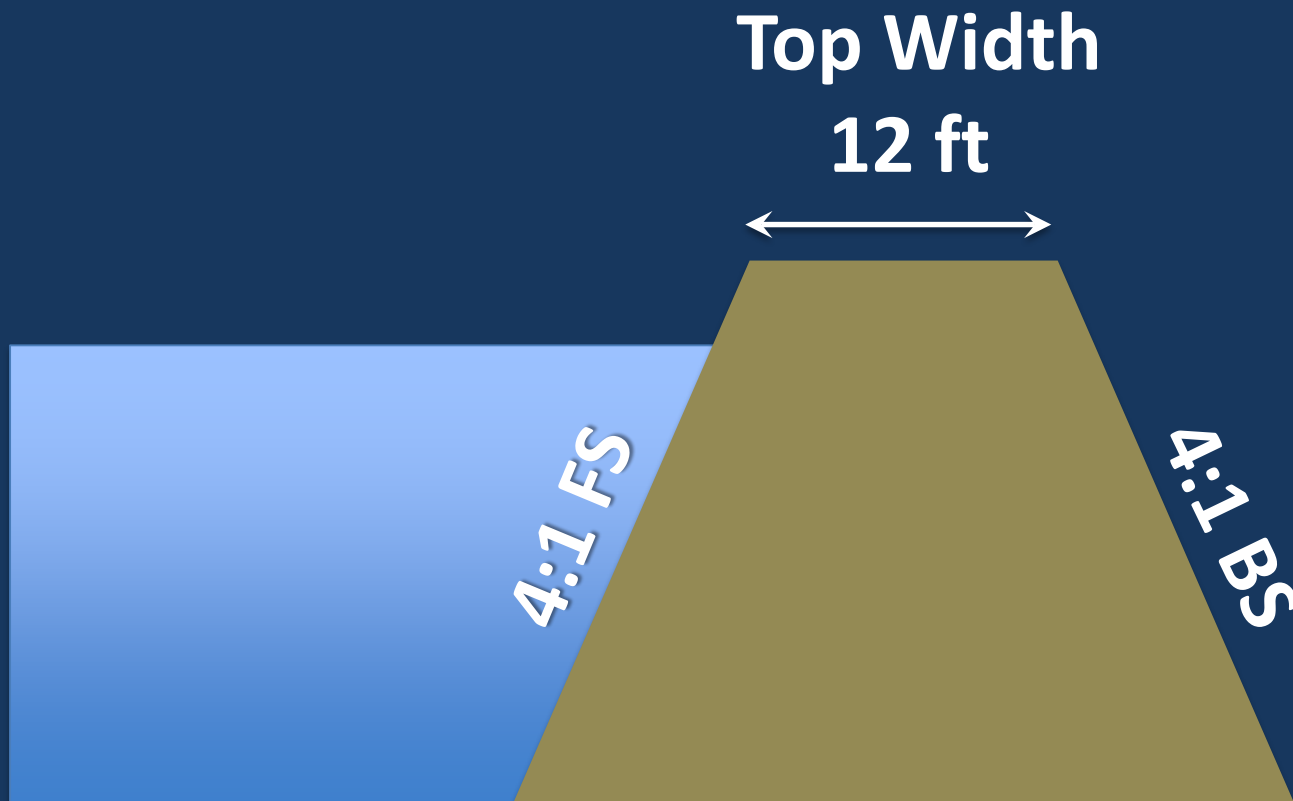

Embankment Template Data

Embankment Template Data
X

Crown in Feet: **0**

Top Width in Feet: **12'**

Side Slope Ratios

Upstream: **4:1**

Downstream: **4:1**

Wave Berm Width, Ft.: **0**

Stability Berm Options:

- No Stab. Berms
- Single Stab. Berm US and DS
- Mult. Stab. Berms US and DS



Auxiliary spillway

Aux Spwy Crest: Options

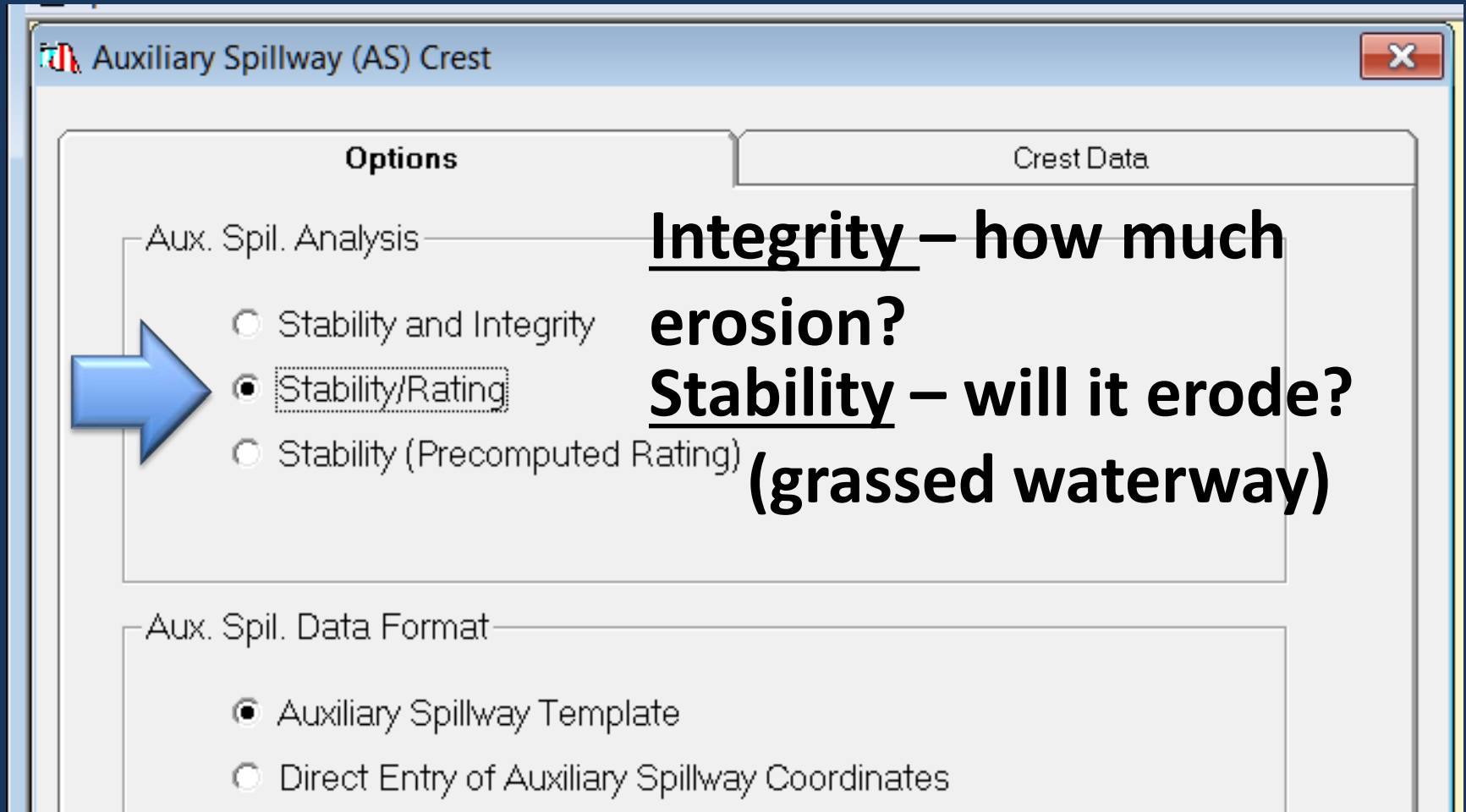

Options Crest Data

Aux. Spil. Analysis

- Stability and Integrity
- Stability/Rating**
- Stability (Precomputed Rating)

Aux. Spil. Data Format

- Auxiliary Spillway Template
- Direct Entry of Auxiliary Spillway Coordinates

Integrity – how much erosion?
Stability – will it erode?
(grassed waterway)

Aux Spwly Crest: Crest Data

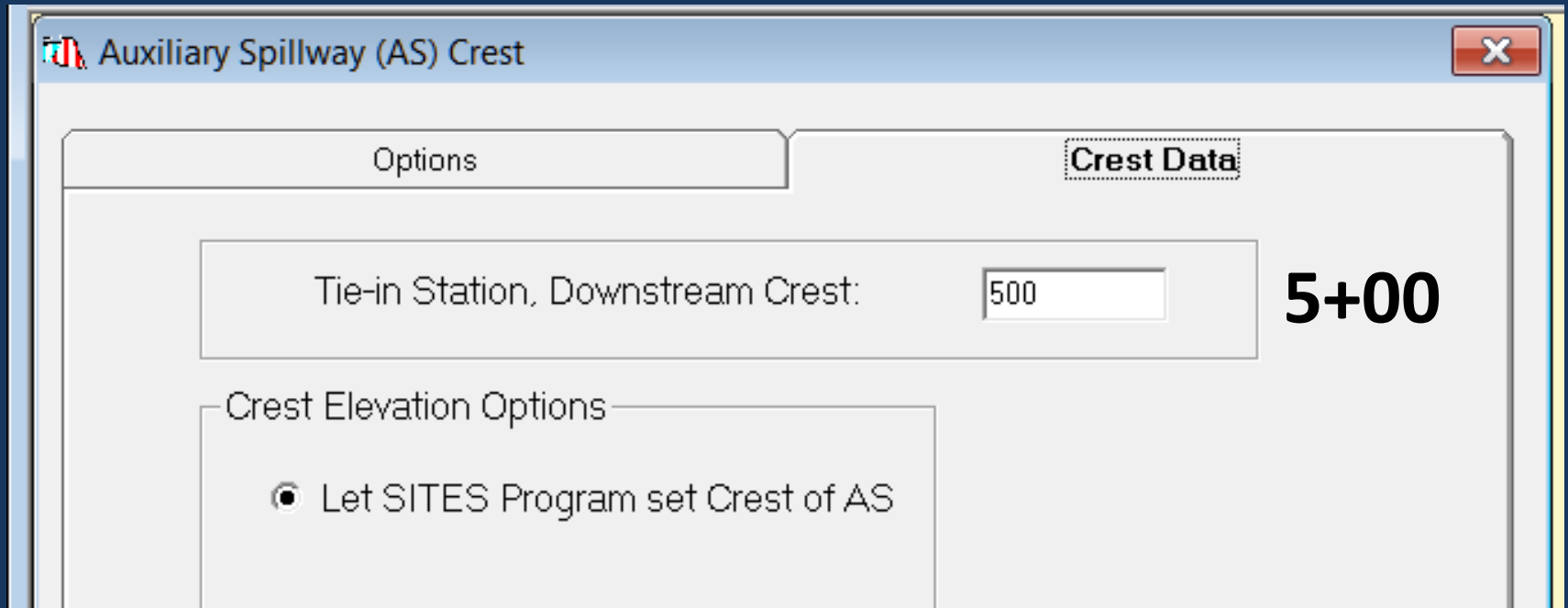

Auxiliary Spillway (AS) Crest

Options Crest Data

Tie-in Station, Downstream Crest: 500 **5+00**

Crest Elevation Options

Let SITES Program set Crest of AS

Auxiliary Spillway Profile

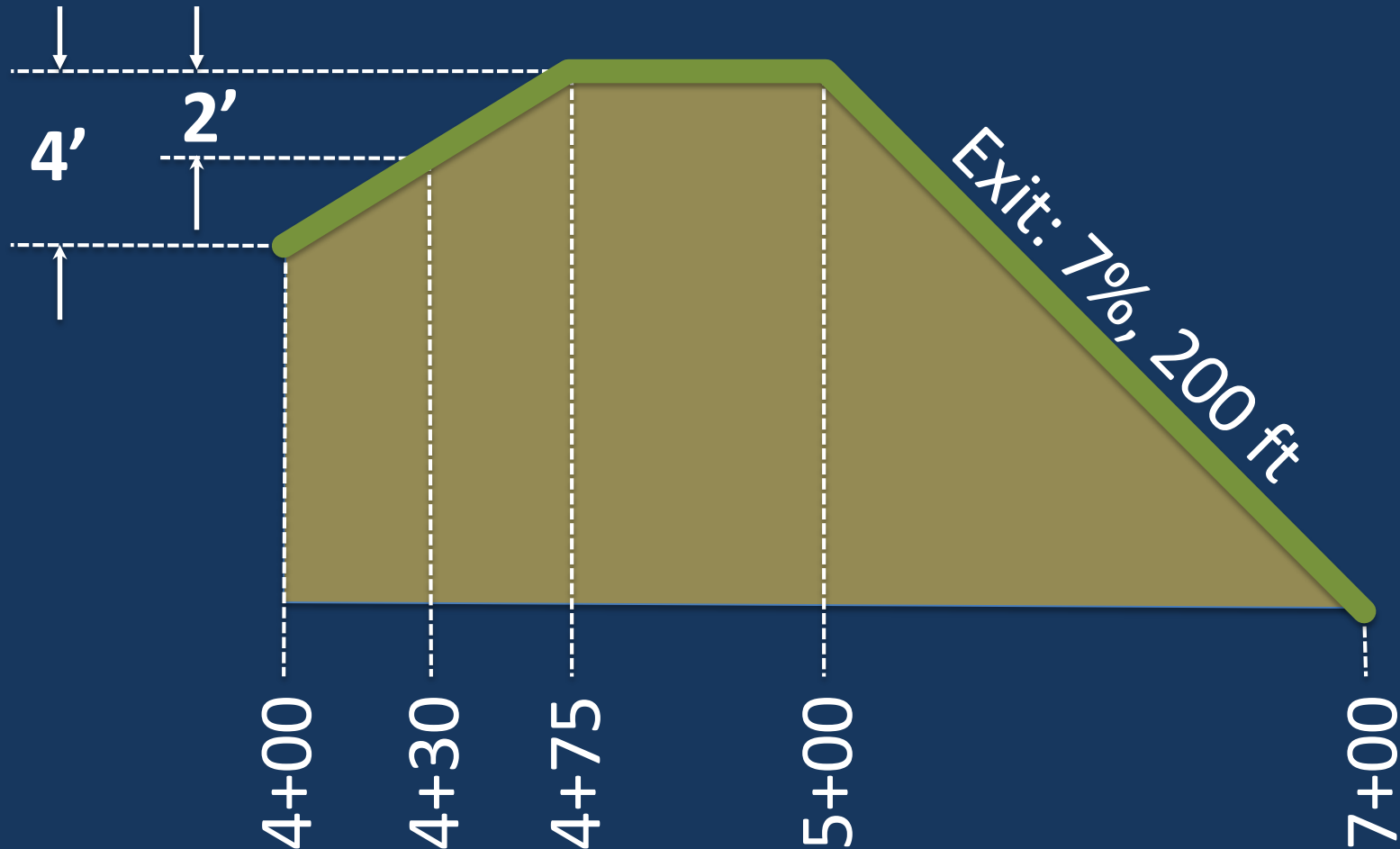

Auxiliary Spillway Section

Veg Ret = 5.6

Veg Cover Factor = 0.8

MC = 1

Root Depth = 1.5 ft

Topsoil Rep Dia = 0.01 ft

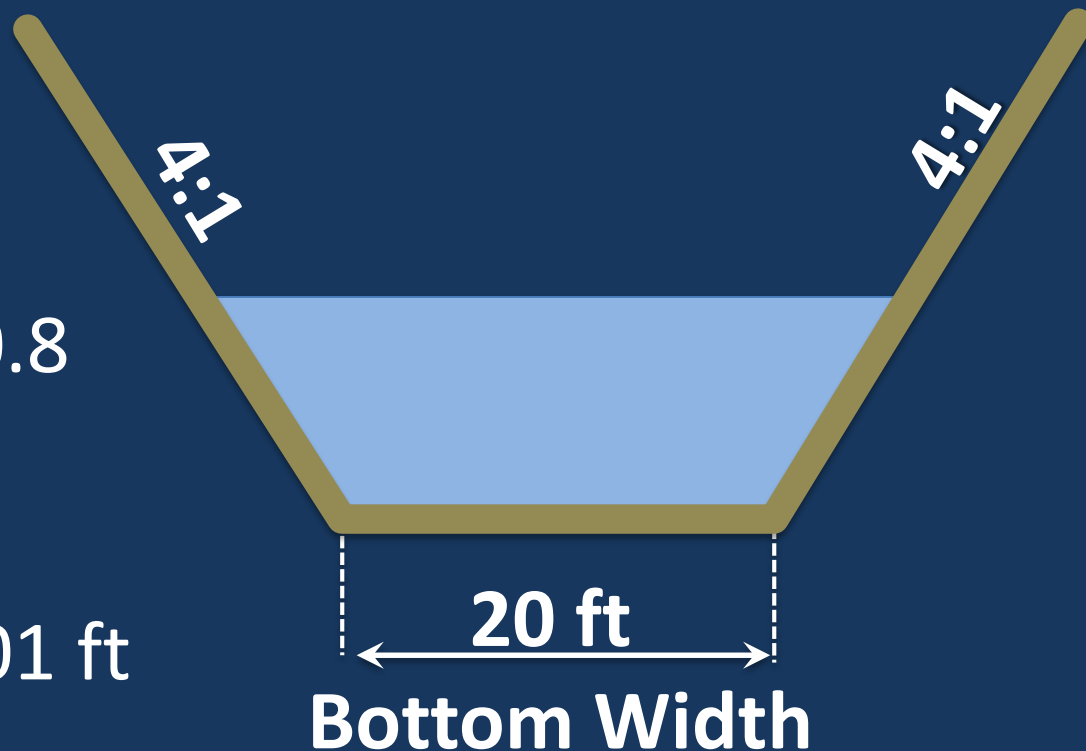

Aux Spwy Inlet Template

Auxiliary Spillway Inlet Template

Manning's "n" or Veg. Retardance, Constructed Inlet Channel:

Inlet Template		Fixed Point
Distance #1:	<input type="text" value="0.0"/>	Station (ft): <input type="text"/>
Distance #2:	<input type="text" value="25"/>	Elevation (ft): <input type="text"/>
Distance #3:	<input type="text" value="70"/>	
Distance #4:	<input type="text" value="100"/>	
Depth #1:	<input type="text" value="0.0"/>	
Depth #2:	<input type="text" value="0.0"/>	
Depth #3:	<input type="text" value="2.0"/>	
Depth #4:	<input type="text" value="4"/>	

Aux Spwy Exit Template

Auxiliary Spillway Exit Template
X

Exit Channel Slope

Location of Fixed Exit Coordinate

Exit Channel Slope:

%
 ft / ft

Description	Const.	Exit Channel
Manning's "n" or Veg. Ret.	5.6	5.6
Vegetal Cover Fact	.8	0.8
Maintenance Code	1	1
Pot. Root Depth(Ft)	1.5	1.5
Topsoil Rep Dia(In)	.01	0.01

Aux Spwy Cross Section

Auxiliary Spillway Cross Section
X

Side Slope Ratio: **4:1**

Bottom Width, Feet: **20 ft**

Aux Spwy Length

Auxiliary Spillway Length
X

Inlet Channel Length, Feet: **100 ft**

Exit Channel Length, Feet: **200 ft**



Natural Resources Conservation Service

Options

Output Options

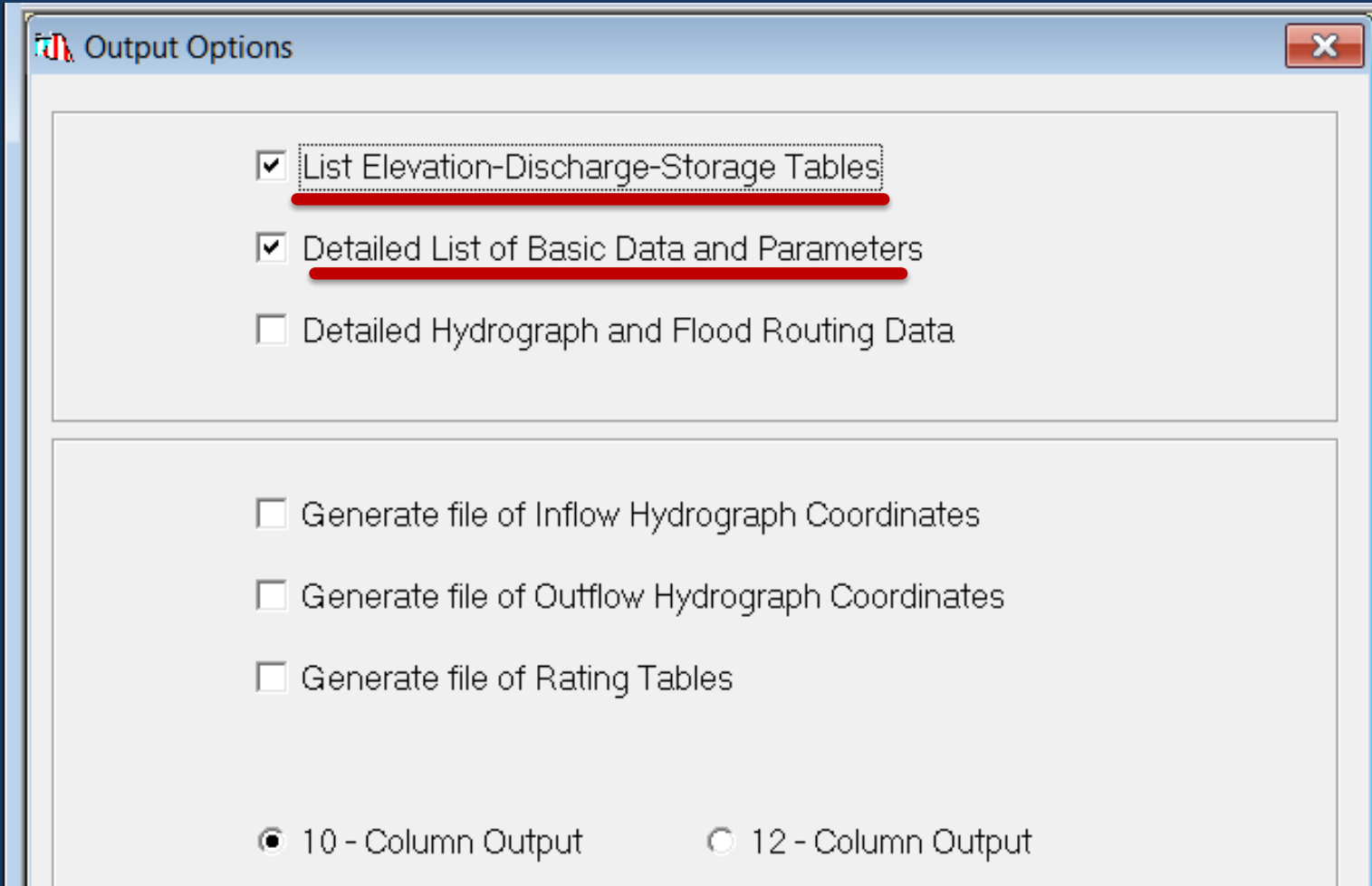

Output Options

- List Elevation-Discharge-Storage Tables
- Detailed List of Basic Data and Parameters
- Detailed Hydrograph and Flood Routing Data

- Generate file of Inflow Hydrograph Coordinates
- Generate file of Outflow Hydrograph Coordinates
- Generate file of Rating Tables

- 10 - Column Output 12 - Column Output



Natural Resources Conservation Service

Output

Summary

	378Pond
Total Watershed Drainage Area (Sq.Miles)	0.08
SDH Rainfall Total (Inches)	N/A
SDH Rainfall Duration (Hours)	N/A
FBH or Storm Rainfall Total (Inches)	7.80
FBH or Storm Rainfall Duration (Hours)	24.0
SDH Inflow Peak (CFS)	N/A
FBH or Storm Inflow Peak (CFS)	115.6
Initial Reservoir Elevation (Feet)	96.00
Maximum WS SDH (Feet)	N/A
Maximum WS FBH or Storm (Feet)	99.07
Top Dam (Feet)	100.16
PSH Drawdown (Days)	0.82
PS Crest (Feet)	96.00
PS Conduit Diameter (Inches)	18.0
AS Crest (Feet)	98.16
AS Width (Feet)	20.
AS Exit Slope (%)	7.00
AS Ret. Curve Index	5.60
AS Veg. Cover Factor	0.80
AS Maintenance Code	1
AS Max. Head SDH (Feet)	N/A
AS Peak Discharge SDH/Storm (CFS)	23.3
Hp FBH or Storm (Feet)	0.91
AS Peak Discharge FBH/Storm (CFS)	23.
Number of Errors	0
Number of Warnings	0

PS Hydrograph Plot

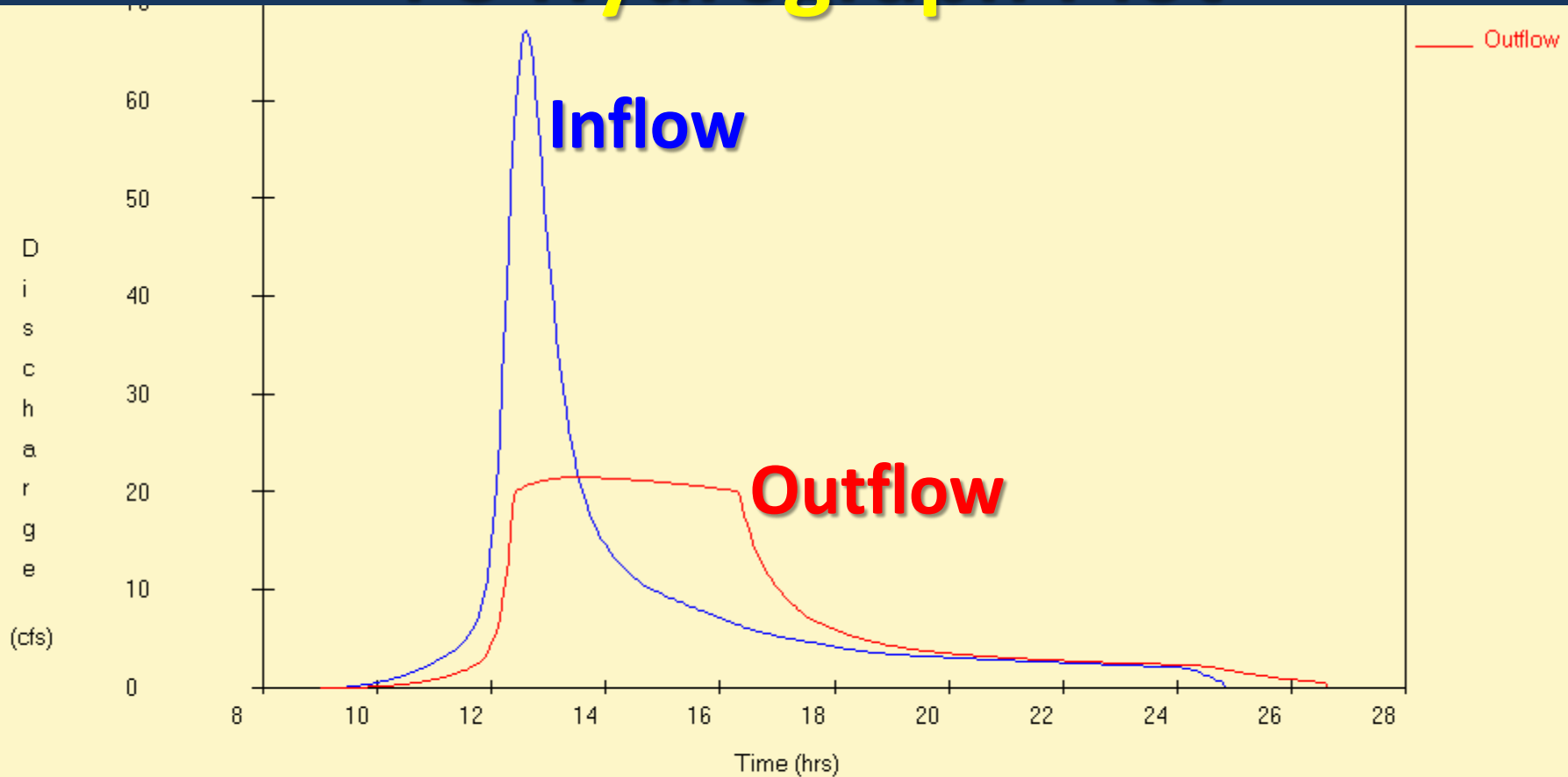

PRIN. SPILLWAY: Crest = 96.00

WS = 101, STR = 1, FILE = 378Pond

Aux Spwly Hydrograph

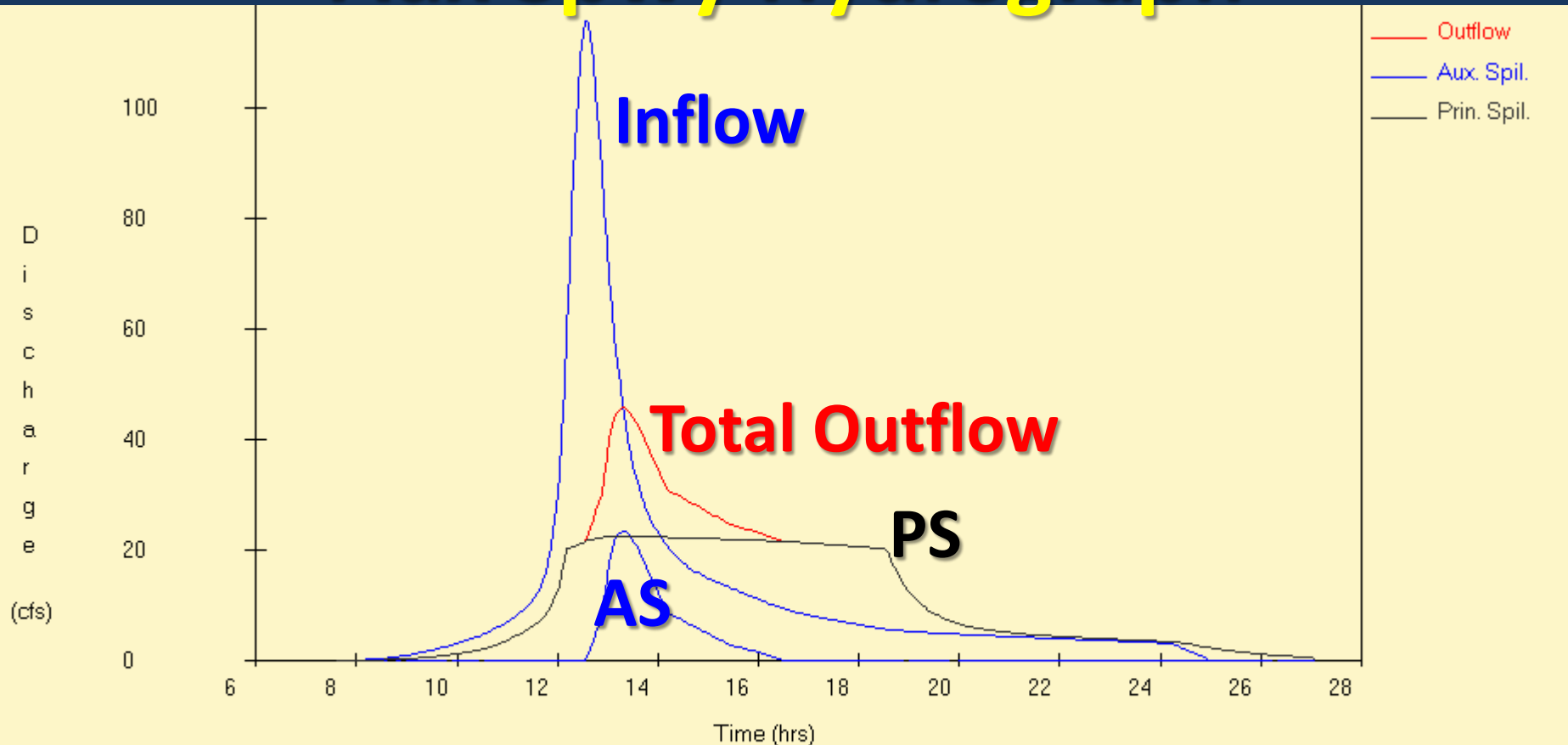

PRIN. SPILLWAY: Crest = 96.00

AUX. SPILLWAY: Crest = 98.16, BW = 20.

WS = 101, STR = 1, FILE = 378Pond

Embankment X-Section

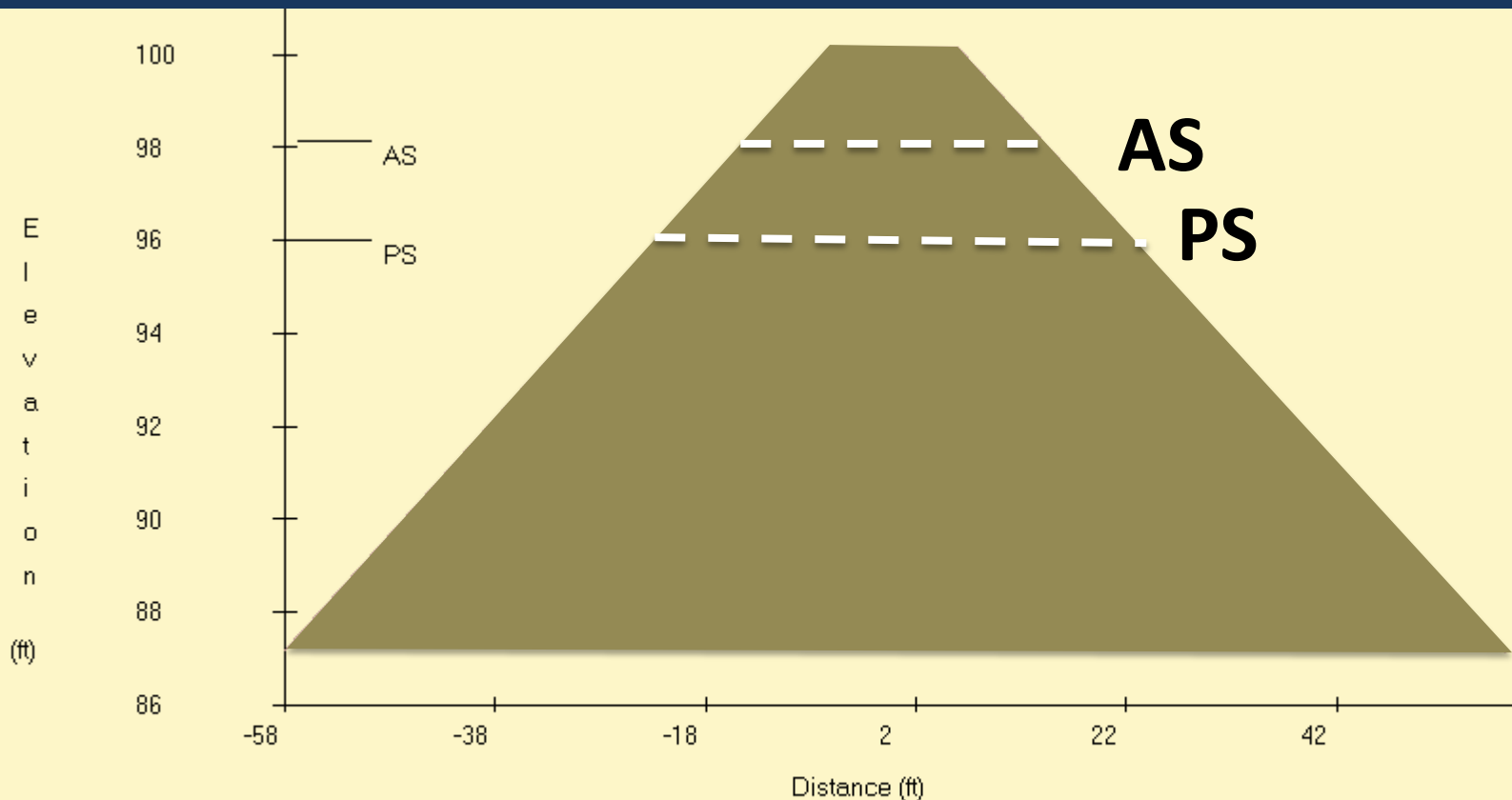

PRIN. SPILLWAY: Crest = 96.00, TOP of DAM = 100.16

AUX. SPILLWAY: Crest = 98.16

WS = 101, STR = 1, FILE = 378Pond

PS (pipe) Rating

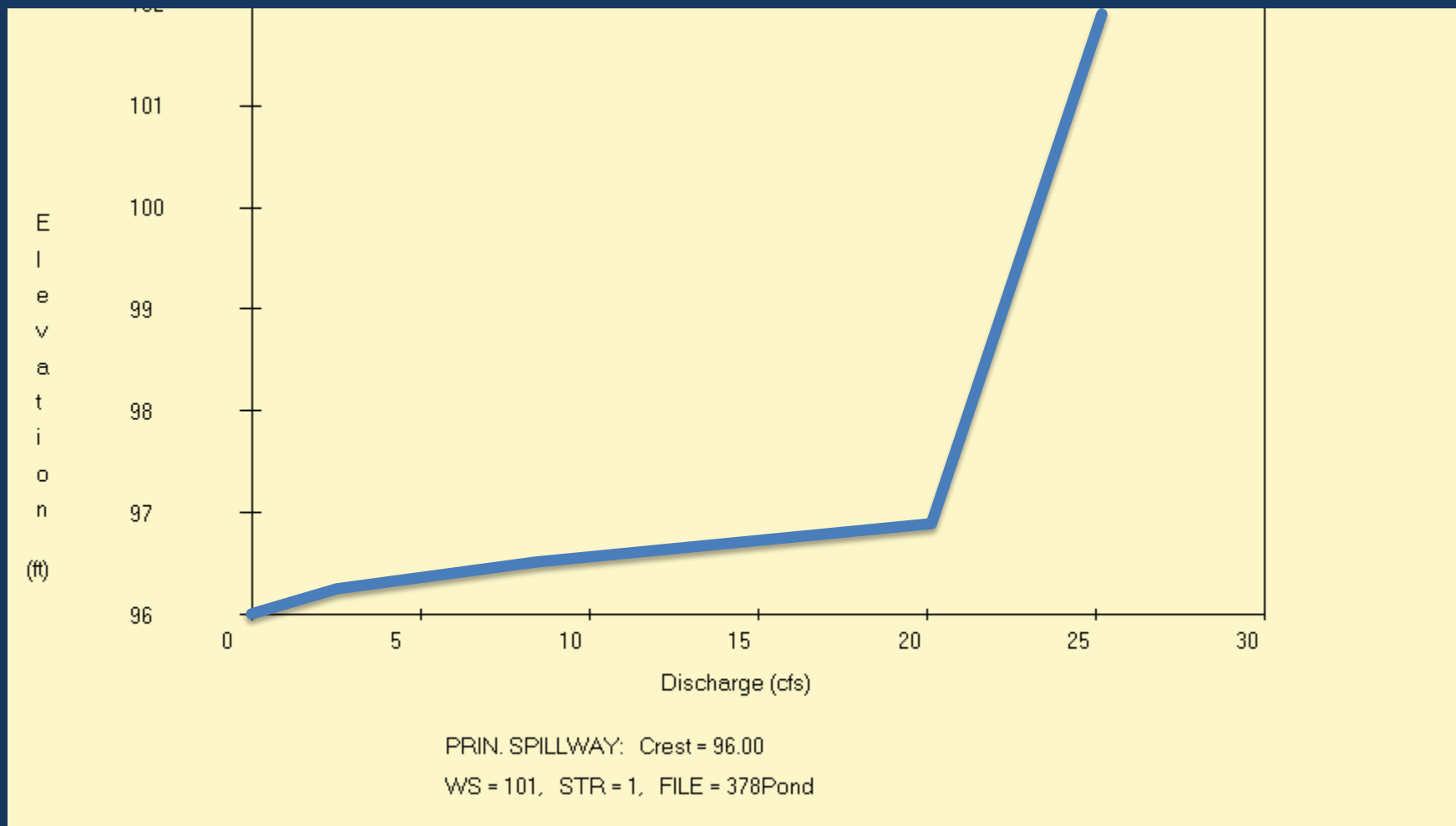

Total Discharge Rating

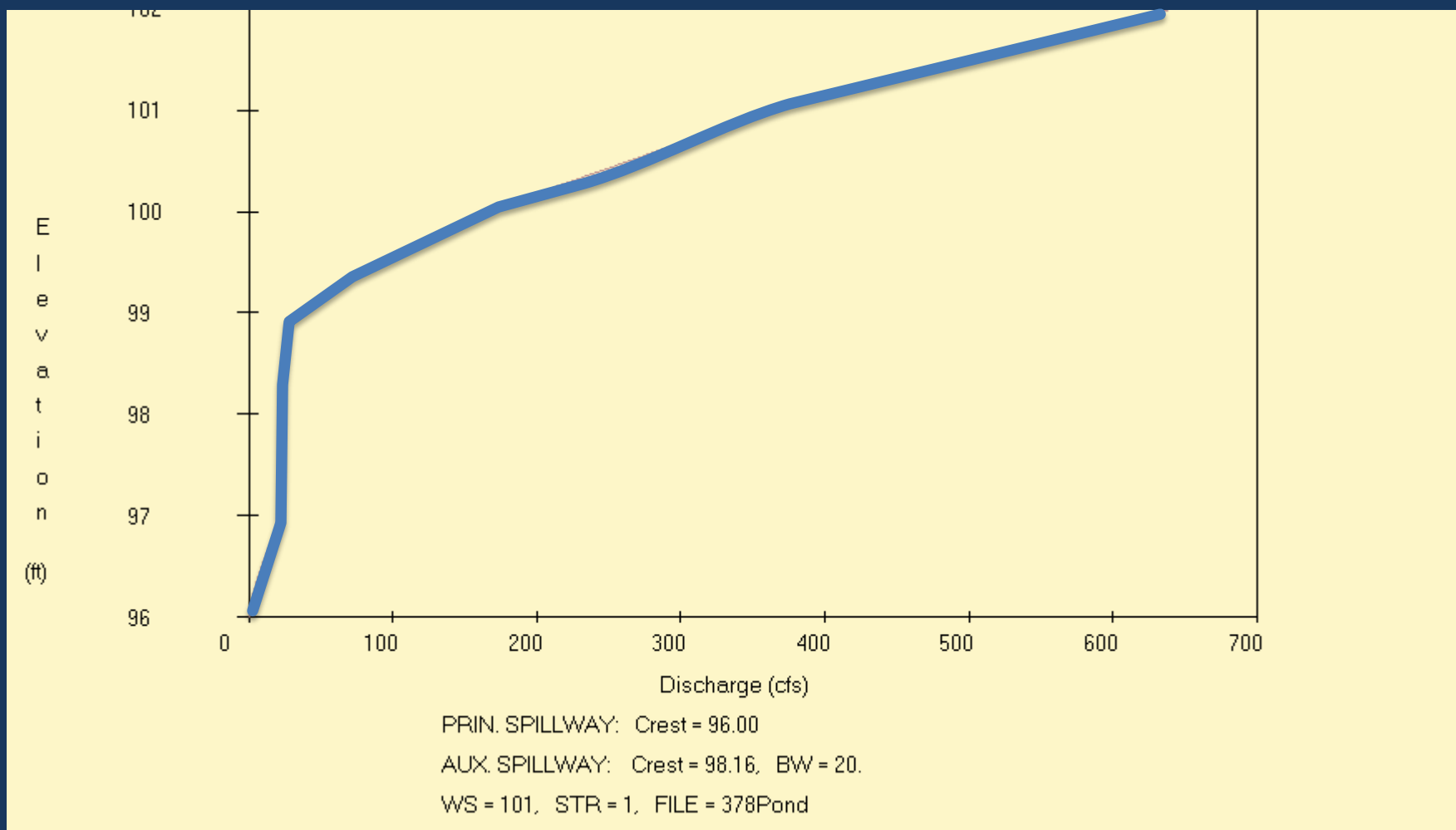

Profile Pond Centerline

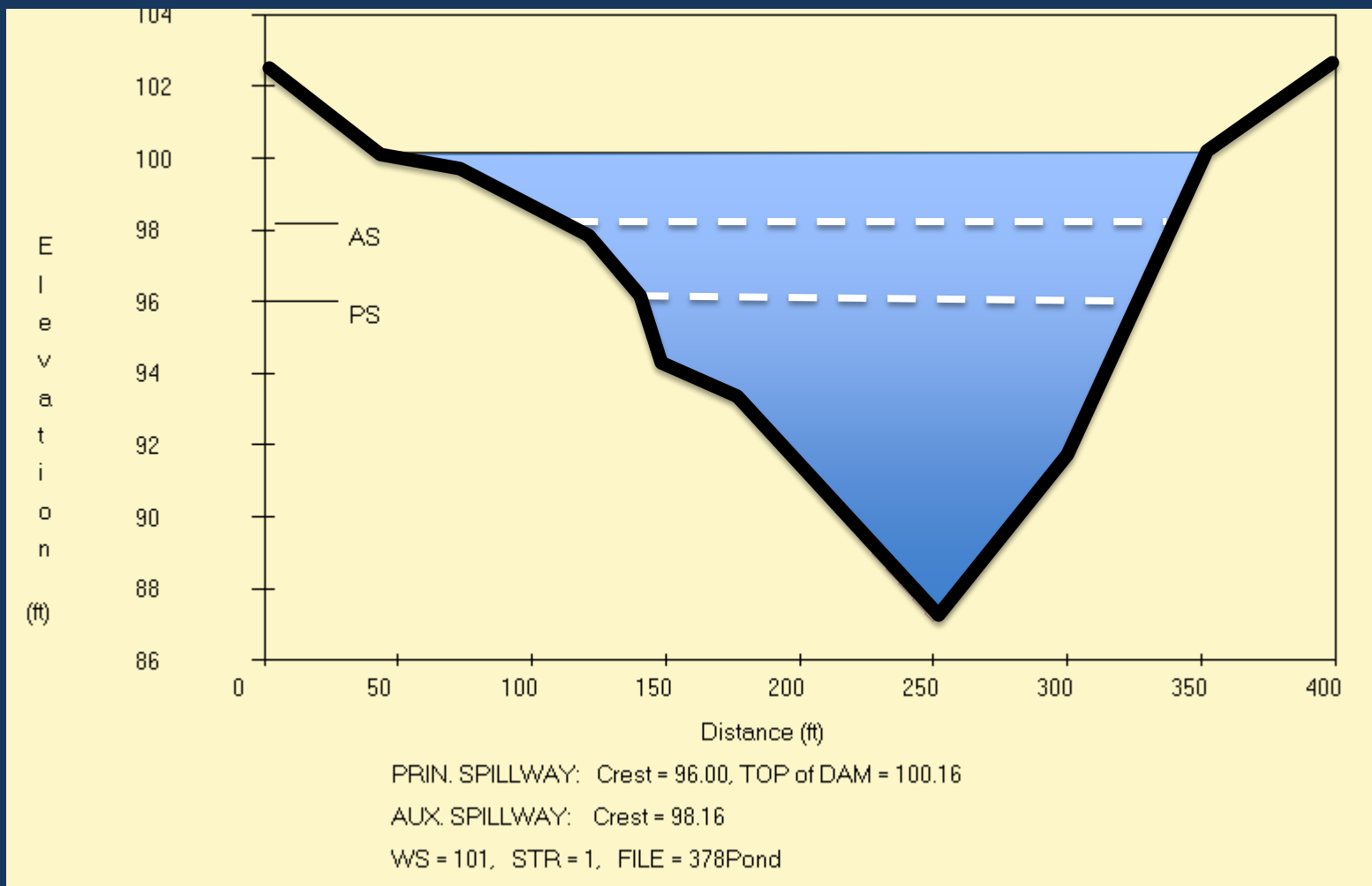



Natural Resources Conservation Service

Text Output

PS (pipe) Routing

PERM POOL	96.00 FT	3.6 ACFT	1.20 AC	2.5 CFS
CREST PS	96.00 FT	3.6 ACFT	1.20 AC	2.5 CFS
SED ACCUM	96.00 FT	3.6 ACFT	1.20 AC	2.5 CFS
START ELEV	96.00 FT	3.6 ACFT	1.20 AC	0.0 CFS

NRCS-PSH D= 24.00 HR P= 5.60 IN Q= 2.58 IN DA= 0.08 SM
 TC= 0.85 HR CN= 71.00 VOL= 10.7 ACFT

PEAK = 67.1 CFS, AT 12.6 HRS.

ROUTED RESULT - HYD TYPE	EMAX	VOL-MAX	AMAX	QMAX
NRCS-PSH	98.16 FT	7.1 ACFT	2.32 AC	21.5 CFS

SITES sets aux spwy crest @ max wse = 98.16 ft

Aux Spwly Routing Inputs

AUX. CREST 98.16 FT 7.1 ACFT 2.32 AC 21.5 CFS

PS STORAGE 3.5 ACFT, BETWEEN AUX. CREST AND SED. ACCUM ELEVATIONS.

START ELEV 96.00 FT 3.6 ACFT 1.20 AC 0.0 CFS

EFFECTIVE HEIGHT(H) = 11.1 FEET, PRODUCT = 79. (H * STORAGE AT CREST AUX.)

INPUT DESIGN CLASS = A1 = LT 3000. PRODUCT.

NRCS-FBH D= 24.00 HR P= 7.80 IN Q= 4.41 IN DA= 0.08 SM

TC= 0.85 HR CN= 71.00 VOL= 18.4 ACFT

PEAK = 115.6 CFS, AT 12.6 HRS.

Aux Spwly Reaches

SUMMARY OF AUXILIARY SPILLWAY SURFACE CONDITIONS USED IN COMPUTATIONS BY REACH

REACH	FROM STA (ft)	TO STA (ft)	SLOPE (%)	RETARDANCE CURVE INDEX	VEGETAL COVER FACTOR	MAINT. CODE	ROOTING DEPTH (ft)	REACH LOCATION *
1	400.	430.	- 6. 7	5. 6	**	**	**	I NLET
2	430.	475.	- 4. 4	5. 6	**	**	**	I NLET
3	475.	500.	0. 0	5. 6	**	**	**	C REST
4	500.	700.	7. 0	5. 6	0. 80	1	1. 5	E XIT !

* Upper case indicates a reach of constructed spillway channel.

** The program does not use vegetal cover factor, maintenance code, and rooting depth for inlet and crest reaches in computations.

! Reach 4 used in computing exit channel velocities.

Aux Spwy Routing Results

ROUTED RESULTS	BTM WIDTH FT	MAX ELEV FT	VOL- MAX ACFT	AREA- MAX AC	AUX. - HP FT	VOL- AUX. ACFT
NRCS- FBH	20.0	99.07	10.1	4.1	0.91	3.0

^^^^ NOTE -- ACTUAL Hp OF 0.91 RAISED TO MEET MIN. 378 CRITERIA.

PEAK - CFS	Q- PS	Q- AUX.	Q- TOT.
DISCHARGE =	22.4	23.3	45.8

Aux Spwy Stability (velocity & stress)

EROSIONALLY EFFECTIVE STRESS FOR STABILITY ANALYSIS OF AUX. EXIT CHANNEL

(Refer to Ag. Handbook 667, Chapt. 3, for allowable stresses.)

Aux. Spillway Discharge = 23. cfs; Bottom Width = 20. ft

REACH NO.	FROM STA	TO STA	SLOPE %	MANNING`S n	VELOCITY ft/s	TOTAL STRESS lb/ft ²	EFFECTIVE STRESS lb/ft ²
4	500.	700.	7.00	0.083	2.54	1.85	0.013

Top of Dam Adjusted

>>>>>NHCP378 RUN-MINIMUM DEPTH, CREST AUX TO TOP OF DAM IS 2.00 FT.
 NEW TOP OF DAM ELEVATION = 100.16.

ROUTED RESULTS	BTM WIDTH FT	MAX ELEV FT	VOL-MAX ACFT	AREA-MAX AC	AUX. HP FT	VOL-AUX. ACFT
MINIMUM AUX.	20.0	100.16	15.4	5.7	2.00	8.3
PEAK - CFS DISCHARGES =			Q-PS	Q-AUX.	Q-TOT.	
			23.5	171.6	195.1	
AUXILIARY SPILLWAY - - -	CRITICAL DEPTH FT	CRITICAL VELOCITY FT/SEC	CRITICAL SLOPE-Sc FT/FT	25% OF Q Sc FT/FT		
	1.21	5.71	0.024	0.073		

Volume of Fill – 3,400 yd³

EMBANKMENT QUANTITIES

VOLUME FILL= 3444. CY,

TOP WIDTH = 12.0 FT,

AREA OF DAM= 0.42 AC,

(PROJECTED HORZ. AREA)

MAX. HEIGHT = 13.1 FT

TOP LENGTH = 310.6 FT

AREA TO SEED= 0.34 AC

Final Design



Final Design





Final Design



Contact

Karl Visser, PE

- 817-509-3763
- karl.Visser@ftw.usda.gov

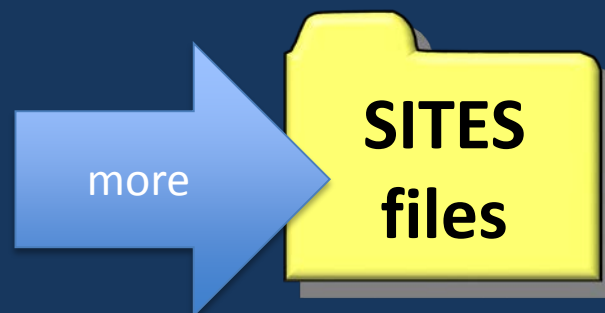

Phuc H. Vu, PE

- 817-509-3764
- phuc.vu@ftw.usda.gov

Natural Resources Conservation Service

A large, bright yellow folder icon with a tab at the top left, centered on a dark blue background. The text "SITES project directories & files" is written in bold black font inside the folder.

SITES project directories & files

SITES File Mgt

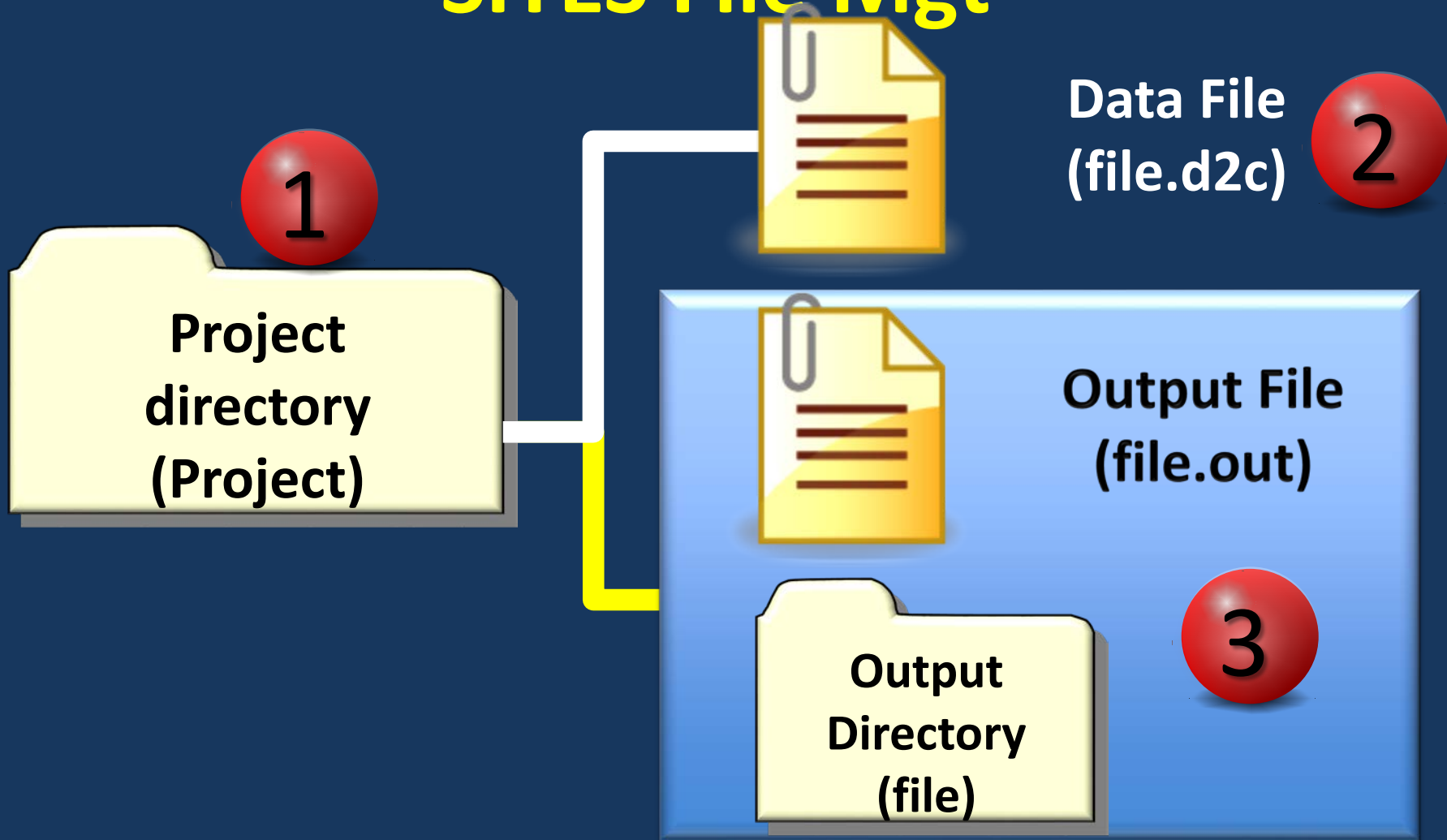

**Project
directory
(Dry Gulch)**

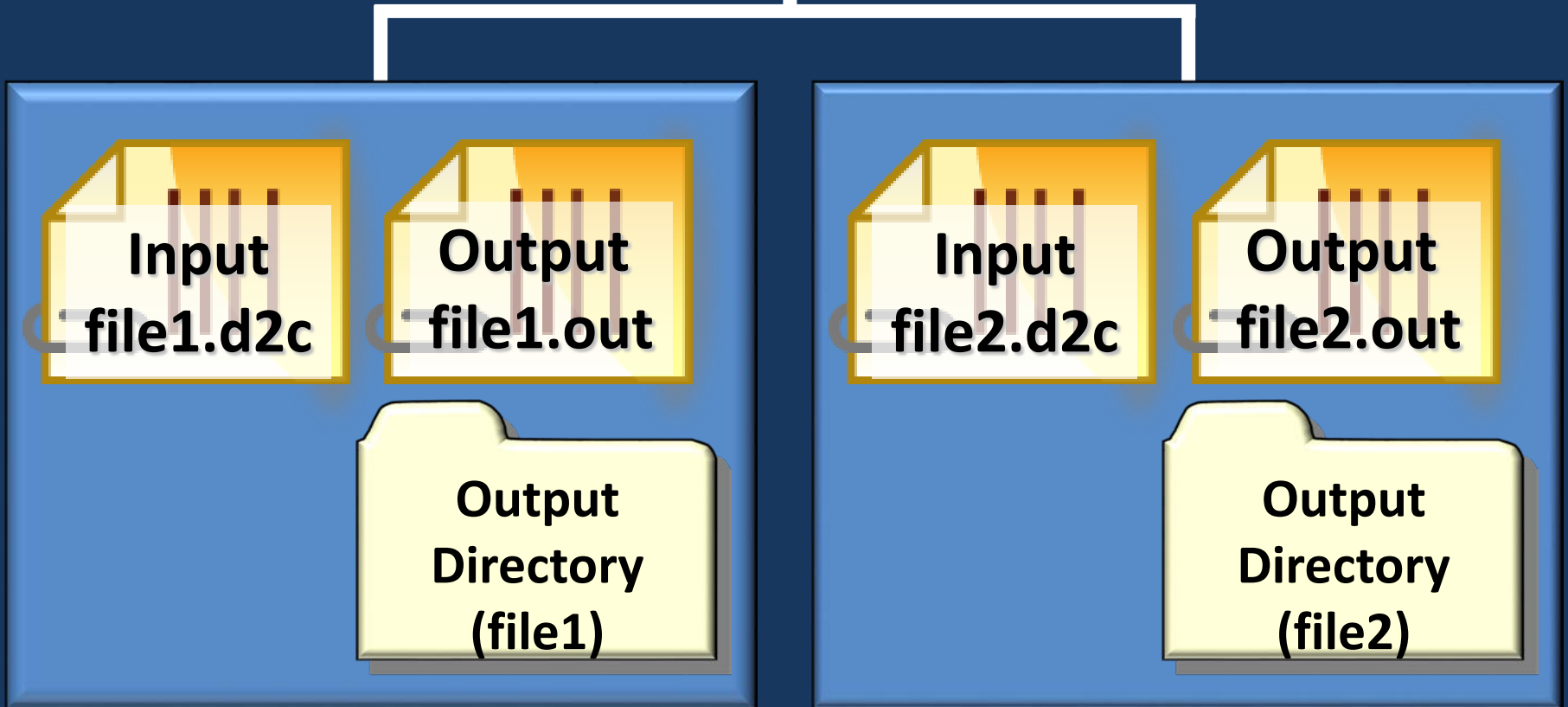

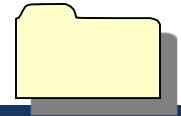

Project Space

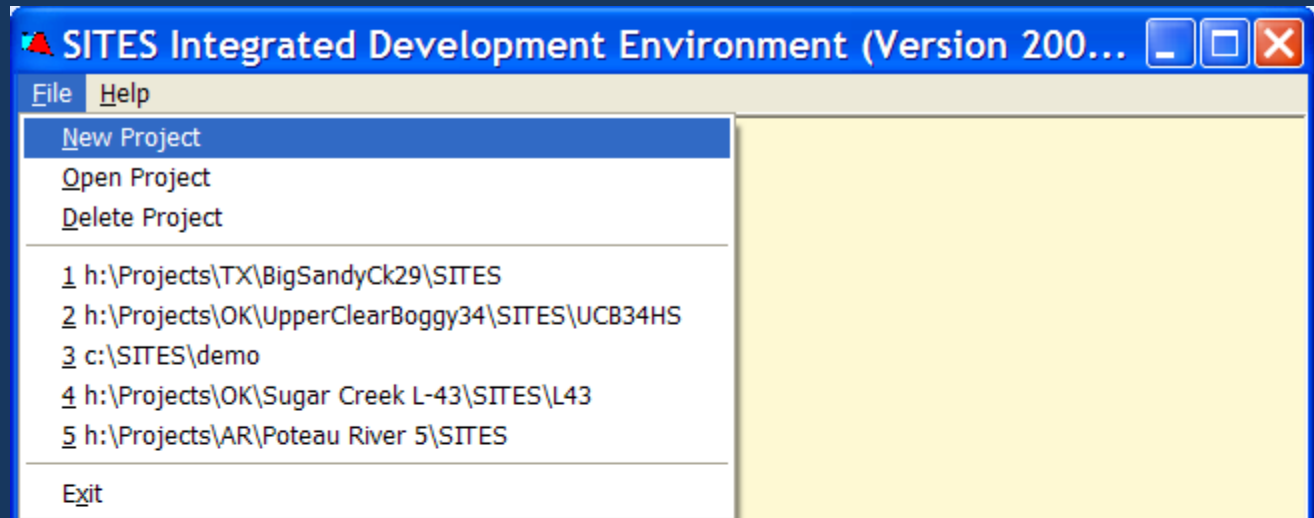

- Deal with SITES projects here
- Create a SITES project (dir)
- Open existing SITES project
- Example SITES project:
 - C:\SITES\Sugar Creek



Data File Screens

SITES Integrated Development Environment [Project: c:\SITES\demo]

File GoTo Build View Options Windows Help

- New File
- Open File
- Import File
- Continue**
- Save As ...
- Exit

- Create New File
- Open existing file
- Import existing file from other prj directory

SITES Input Interface [C:\SITES\demo\Lk_G...

**Home
Screen**

S
I
T
E
S

2005.1

Water Resources Site Analysis Program

Agricultural
Research
Service

NRCS Natural Resources
Conservation Service

Kansas
State
University

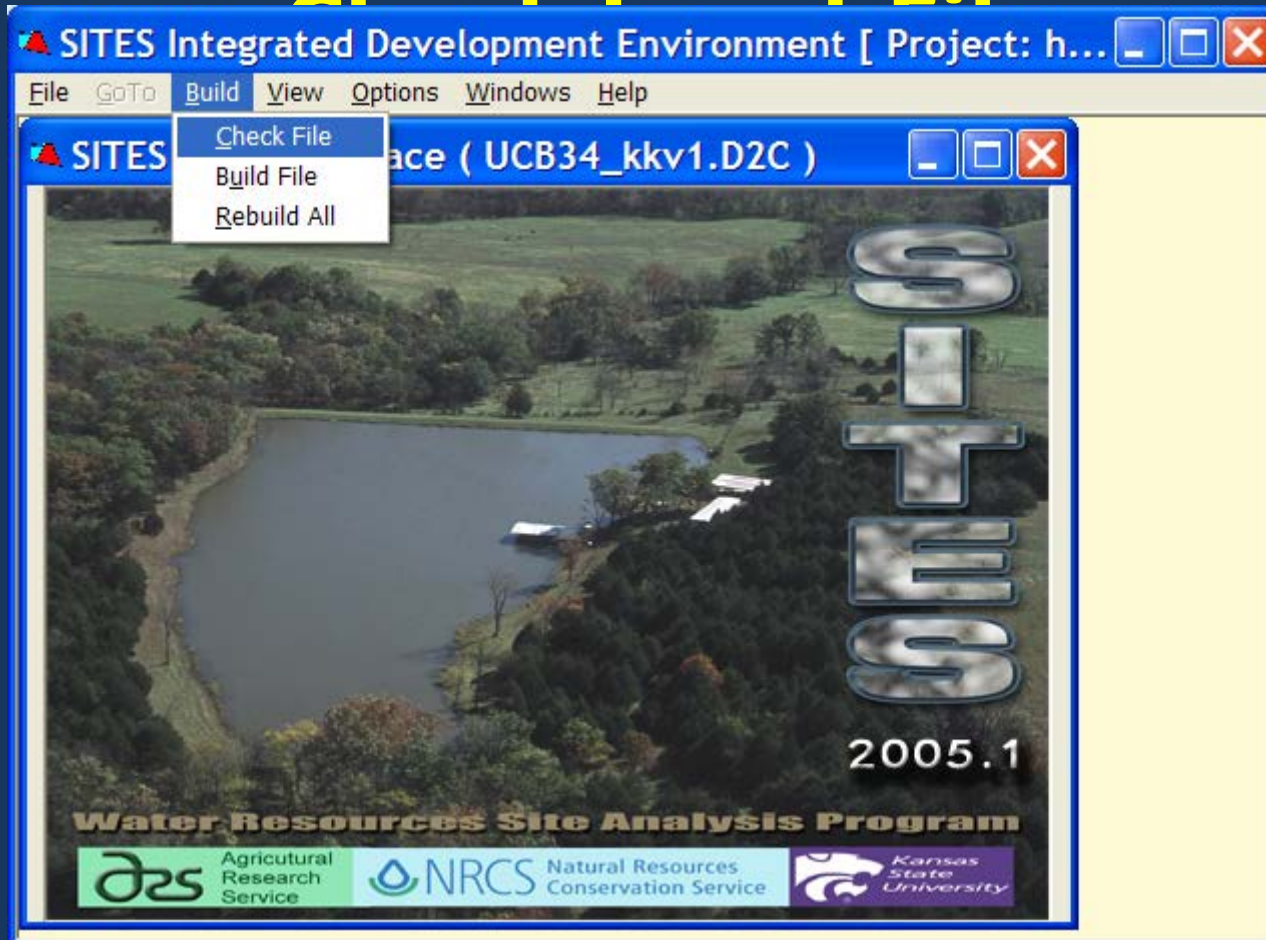

SITES Integrated Development Environment [Project: h:\Projects\OK...

File Edit Windows Help

Integrity Check

Number	Element ID	Error/Warning Code	Error/Warning Message	Screen Name	Control Word	Current Value
1	Structure: UCB36	3146	Value of the last Reach Ending Station must correspond to the last entry in the Station table of the Aux. Spillway Surface Profile.	Aux. Spillway Surface	ASSURFACE	400
2	Structure: UCB35	3146				325
3	Subwatershed: BR	3073				0

SITES Integrated Development Environment [...]

File Edit Help

Auxiliary Spillway Surface Conditions

End of Const. Exit Channel:

Dia. Surface Material, In.:

	Reach Station Beginning	Reach Station Ending	Veg. Retrd Curve Indx	Veg. Cover Factor	Maintenance Code	Potential Root Depth, Ft.
1	220	400	.05	.9	2	.5
2						

Dbl-click –
jump to screen

Create Output - Build

- Save Data File
 - From Home Screen
- BUILD File
 - *AKA run, compute or calculate*

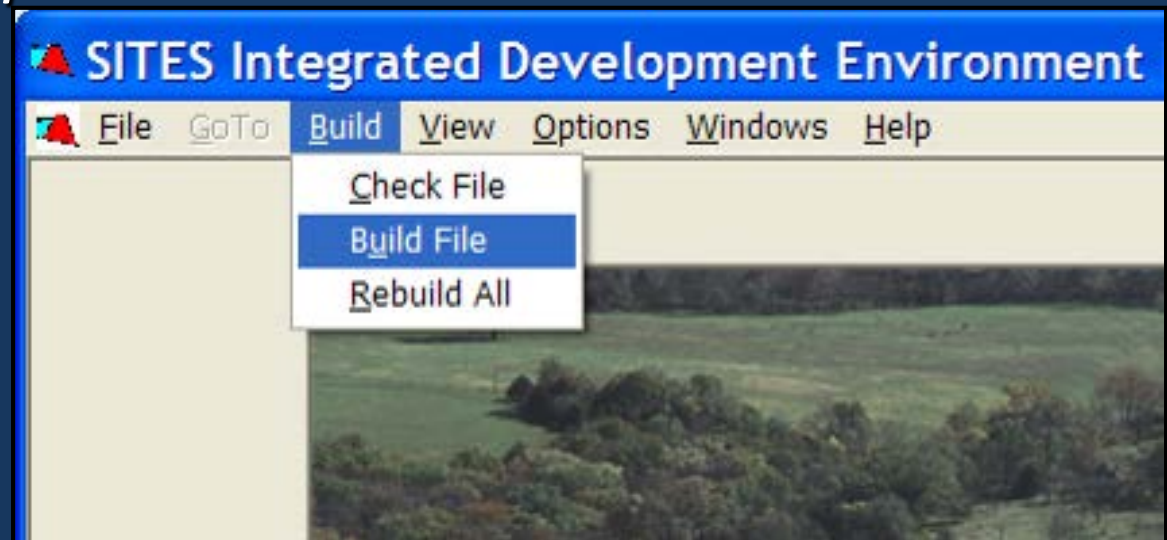

SITES Output Types

SITES Integrated Development Environ...

File View Windows Help

	IDELEFTNATIVEC	HFBHR2NATIVEC
Site Identification	29	29
Watershed Runoff Curve Number	66.	66.
Total Watershed Drainage Area (Sq. Miles)	2.93	2.93
Water	3.12	3.12
SD	N/A	8.02
SD	N/A	6.0
FBH	17.23	12.58
FBH	24.0	6.0
SDH Inflow Peak (CFS)	N/A	1868.1
FBH	2347.7	2007.0

Summary Table

SITES Integrated Development Environment [Project: h:\Projec...]

File Edit Settings Windows Help

1 SUMMARY TABLE 1 SITES VERSION 2005.1.04
DATED 01/01/2005

WATERSHED ID RUN DATE RUN TIME

BS29 06/11/2009 09:05:42

>>>	SITE ID	SUBWS ID	SUBWS DA (SQ MI)	CURVE NO.	TC (HRS)	TOTAL DA (SQ MI)	TYPE DESIGN	STRUC CLASS	<<<
	29	29	2.93	66.	3.12	2.93	TR60	A3	

PASS NO.	DIA./ WIDTH (IN/FT)	AUX.CREST ELEV (FT)	BTM. WIDTH (FT)	MAX. HP (FT)	MAX. ELEV (FT)	EMB. VOL. (CY)	INTEGR.* DIST. (FT)	EXIT* VEL. (FT/SEC)	TYPE HYD
1	24.0	898.5	150.0	3.1	901.6	0.	111.	9.6	NRCS-FBH

Text File

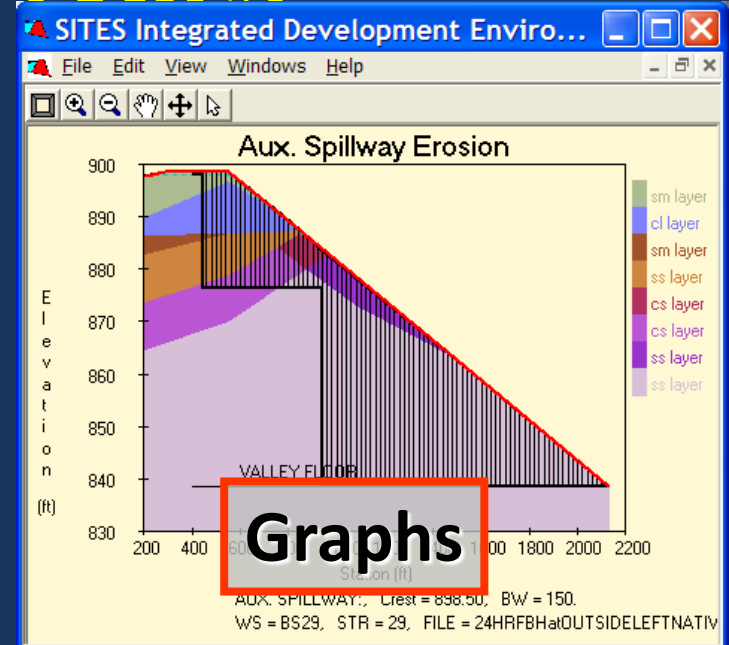

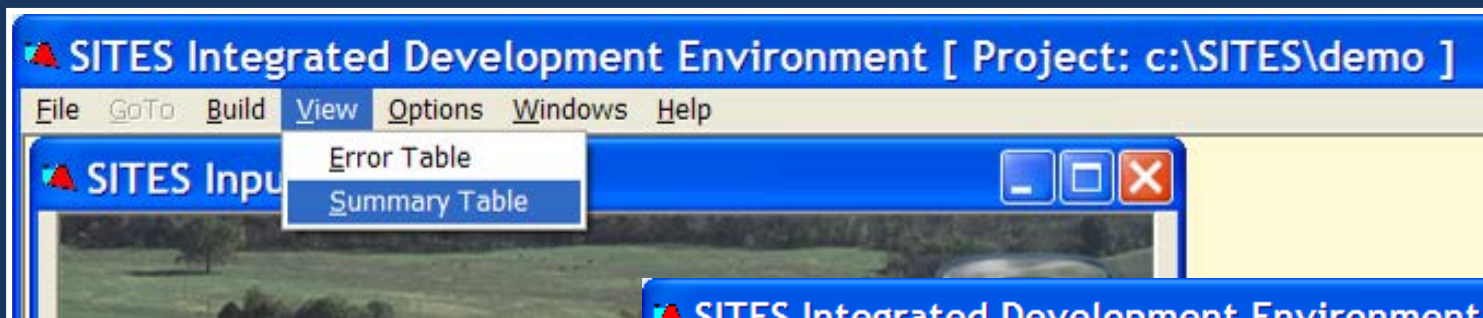

View →
Summary Table

	UCB34_kkv	UCB34_kkv1	UCB34_kkv2
Site Identification	UCB34	UCB34	UCB34
Watershed Runoff Curve Number	80.	80.	80.
Total Watershed Drainage Area (Sq.Miles)	5.45	5.45	5.45
Watershed Time of Concentration (Hours)	4.03	4.03	4.03
SDH Rainfall Total (Inches)	12.48	12.48	12.48
SDH Rainfall Duration (Hours)	6.0	6.0	6.0
FBH or Storm Rainfall Total (Inches)	29.20	29.20	29.20
FBH or Storm Rainfall Duration (Hours)	6.0	6.0	6.0
SDH Inflow Peak (CFS)	4032.6	16087.3	16086.7
FBH or Storm Inflow Peak (CFS)	18873.8	18873.8	16090.5
Initial Reservoir Elevation (Feet)	865.70	865.70	865.70
Maximum WS SDH (Feet)	880.55	880.86	880.89
Maximum WS FBH or Storm (Feet)	883.72	883.73	882.37

View Graphs View Text Summary Graphs Delete Delete All

Graphs

- Summary table displays all files
- Select 1 file
 - Click col header

View Graphs

	IDELEFTNATIVEC	HFBHR2NATIVEC
Site Identification	29	29
Watershed Runoff Curve Number	66.	66.
Total Watershed Drainage Area (Sq.Miles)	2.93	
Watershed Time of Concentration (Hours)	3.12	12
SDH Rainfall Total (Inches)	N/A	32
SDH Rainfall Duration (Hours)	N/A	
FBH or Storm Rainfall Total (Inches)	17.23	12.5
FBH or Storm Rainfall Duration (Hours)	24.0	6.0
SDH Inflow Peak (CFS)	N/A	1868.1
FBH or Storm Inflow Peak (CFS)	2217.7	2297.6

Text Output

View Text

```

SITES Integrated Development Environment [ Project: h:\Pro...
File Edit Settings Windows Help
SITES...COMPUTATIONS COMPLETE

1          SUMMARY TABLE 1          SITES VERSION 2005.1.04
          -----                    DATED 01/01/2005

WATERSHED ID          RUN DATE          RUN TIME
-----
BS29                  06/11/2009          09:05:42

>>>  SITE  SUBWS  SUBWS DA  CURVE  TC  TOTAL DA  TYPE  STRUC  <<<
      ID   ID    (SQ MI)  NO.    (HRS) (SQ MI)  DESIGN  CLASS
-----
      29   29    2.93    66.    3.12  2.93    TR60    A3

PASS  DIA./  AUX.CREST  BTM.  MAX.  MAX.  EMB.  INTEGR.*  EXIT*  TYPE
NO.   WIDTH  ELEV      WIDTH  HP    ELEV  VOL.  DIST.    VEL.   HYD
      (IN/FT) (FT)    (FT)   (FT)   (FT)  (CY)  (FT)  (FT/SEC)
-----
      1   24.0  898.5    150.0  3.1   901.6  0.    111.    9.6   NRCS-FBH
  
```

ASCII

file.out

SITES Project Creation

- SITES tracks projects and data files
- Use SITES to create project directory!
- **Don't use Windows Explorer to create SITES project directory!**

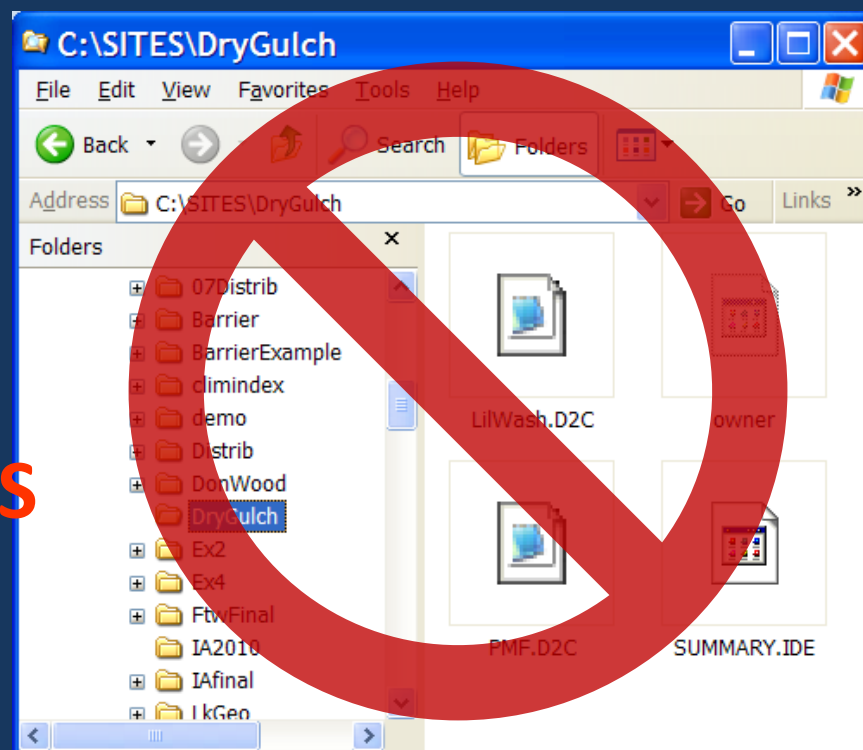

Create New Project

- File → New Project
- Browse to parent directory
- Type in name of new SITES project directory at cursor
- Project Name label appears

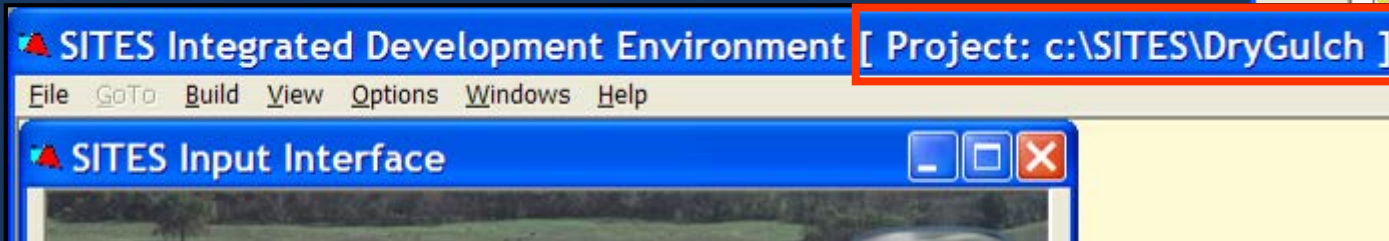
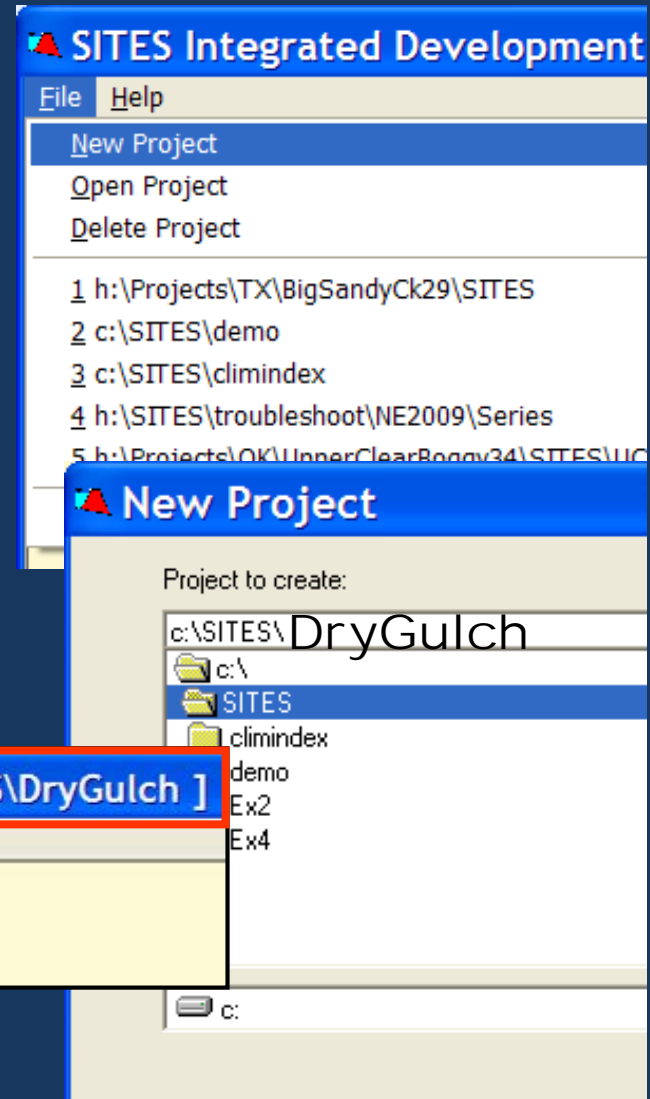

New Folder Contents

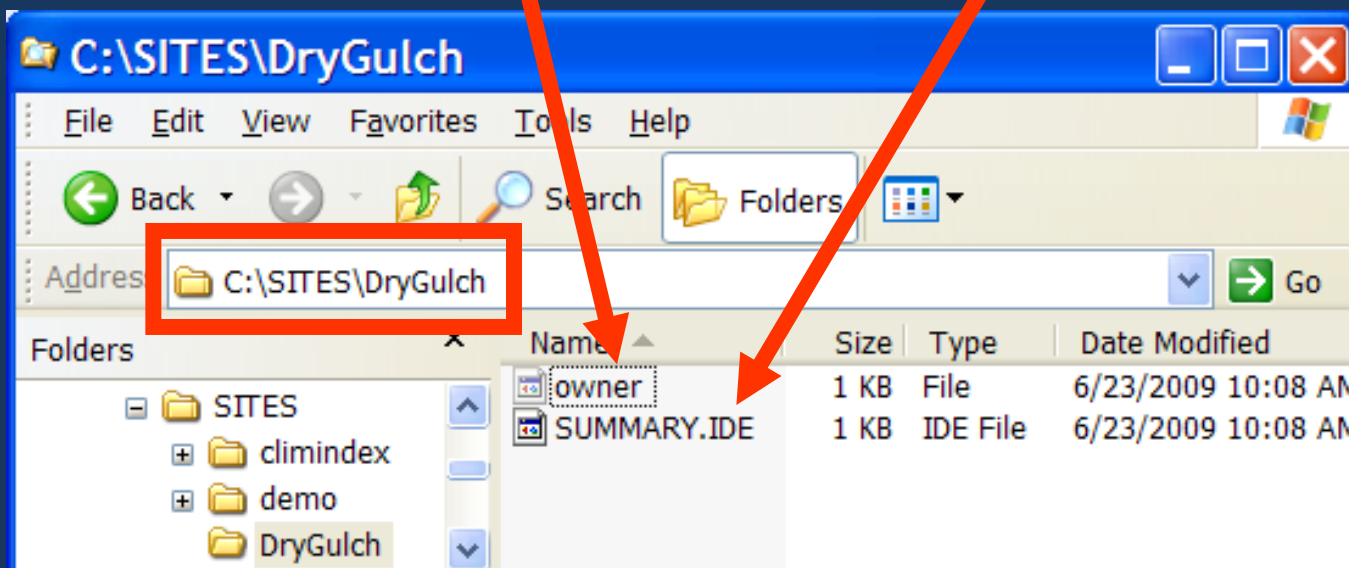
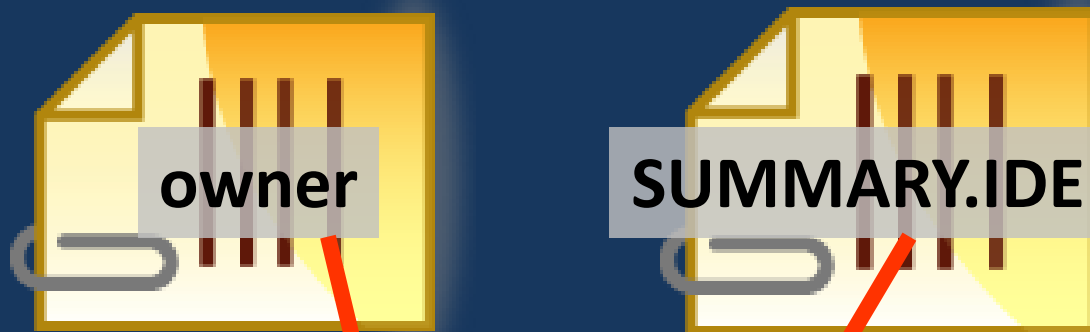

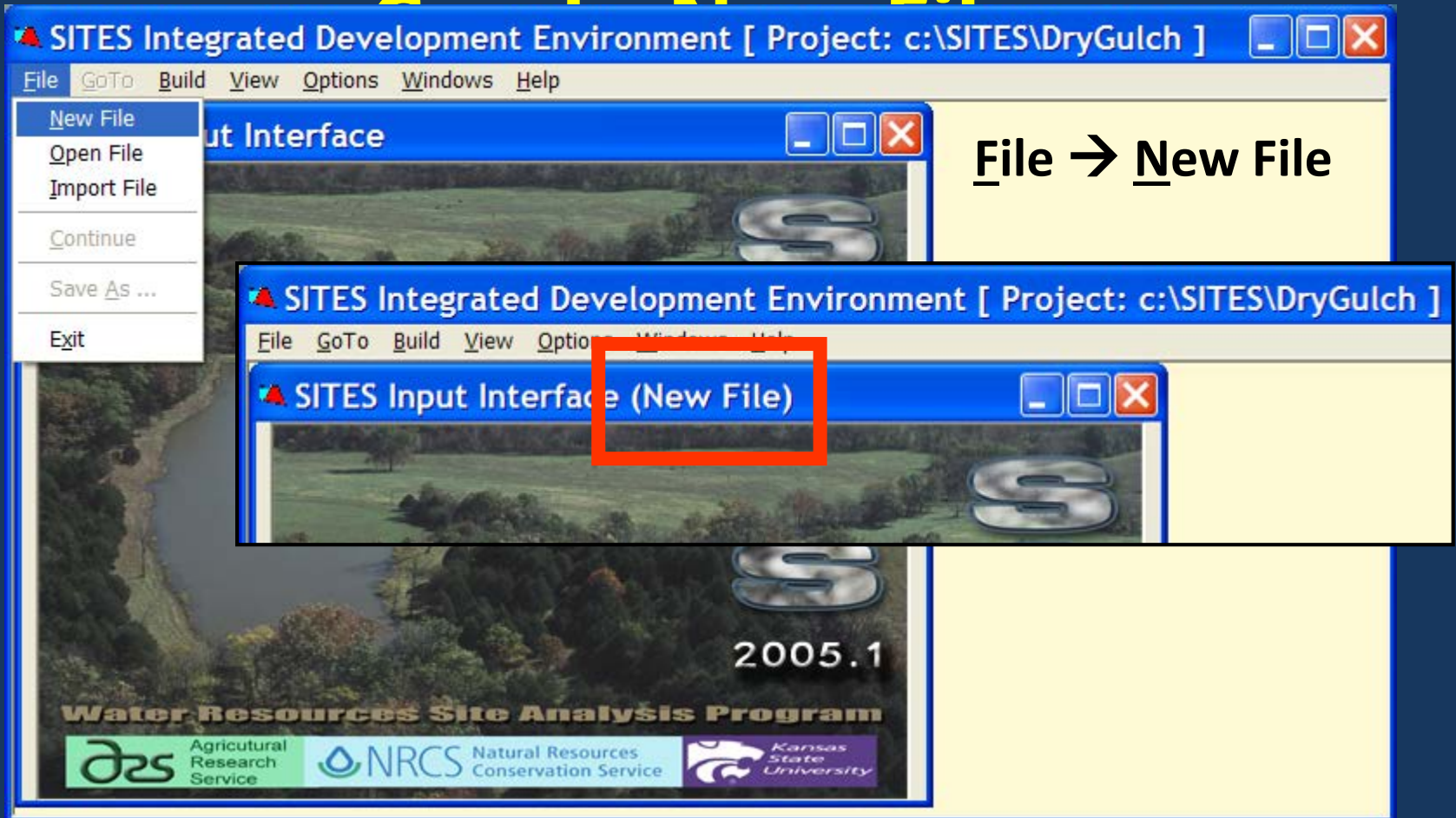

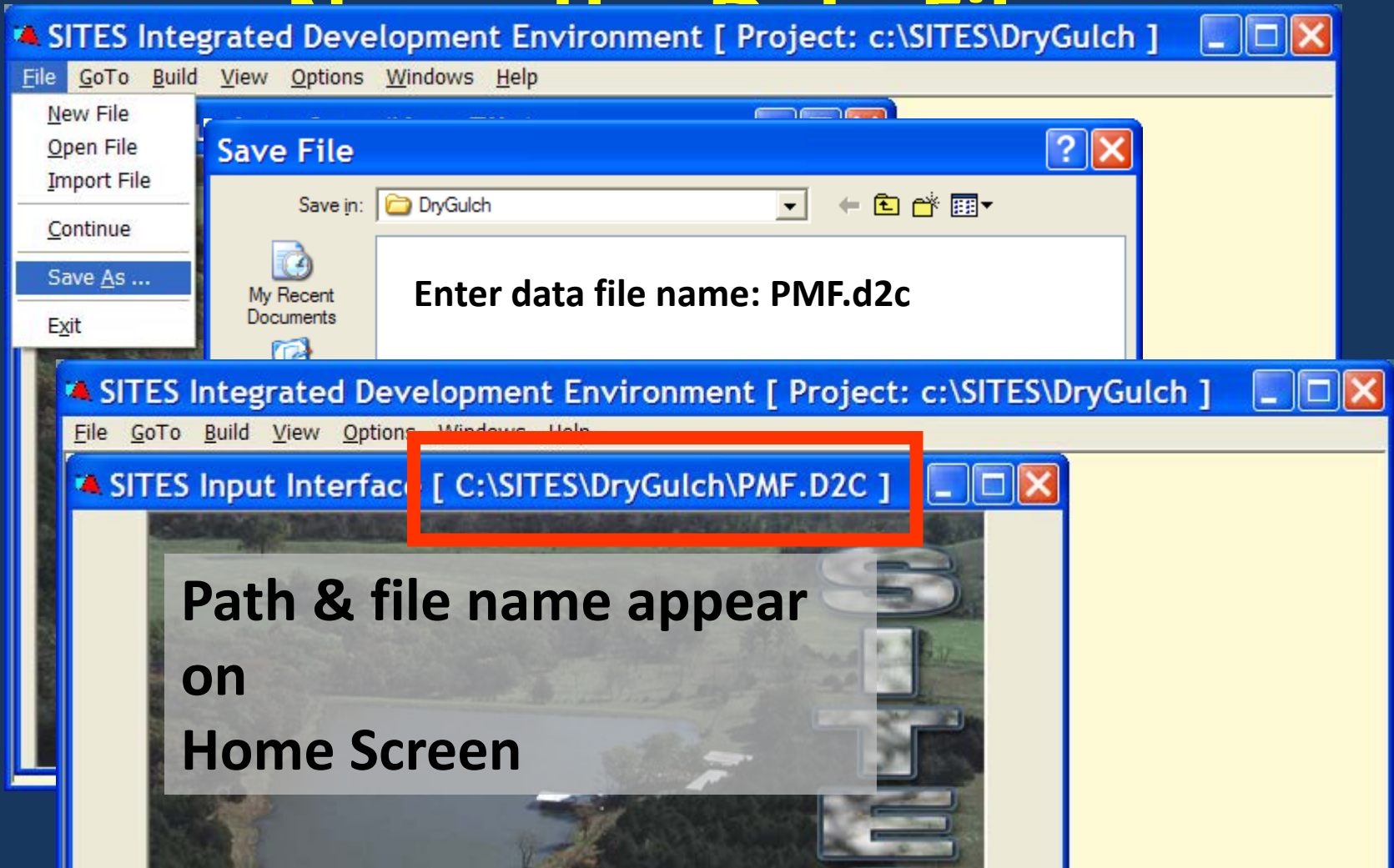

SITES Integrated Development Environment [Project: c:\SITES\DryGulch]

File GoTo Build View Options Windows Help

- New File
- Open File
- Import File
- Continue**
- Save As ...
- Exit

PMF File is opened
File name (PMF.d2c) shows
on Home Screen

File → Continue

SITES Integrated Development Environment [Project: c:\SITES\DryGulch]

File Help

Global Watershed Data

WATERSHED ID

TITLE

Project name and screen name displayed
File name NOT displayed

NRCS (TR-60)

Jump Direct to Screen

Right-click Menu

GoTo

- Principal Spillway (AS) Crest
- Auxiliary Spillway Cross Section
- Auxiliary Spillway Surface Conditions
- Auxiliary Spillway Surface Profile
- Output Options
- Pool Data
- Principal Spillway: Conduit
- Principal Spillway Type
- Rainfall Data
- Structure Data Table
- Valley Elevations
- Watershed Data
- ✓ Watershed Information
- Watershed Schematic

**Alphabetic order
A-Z**

Data File in Folder

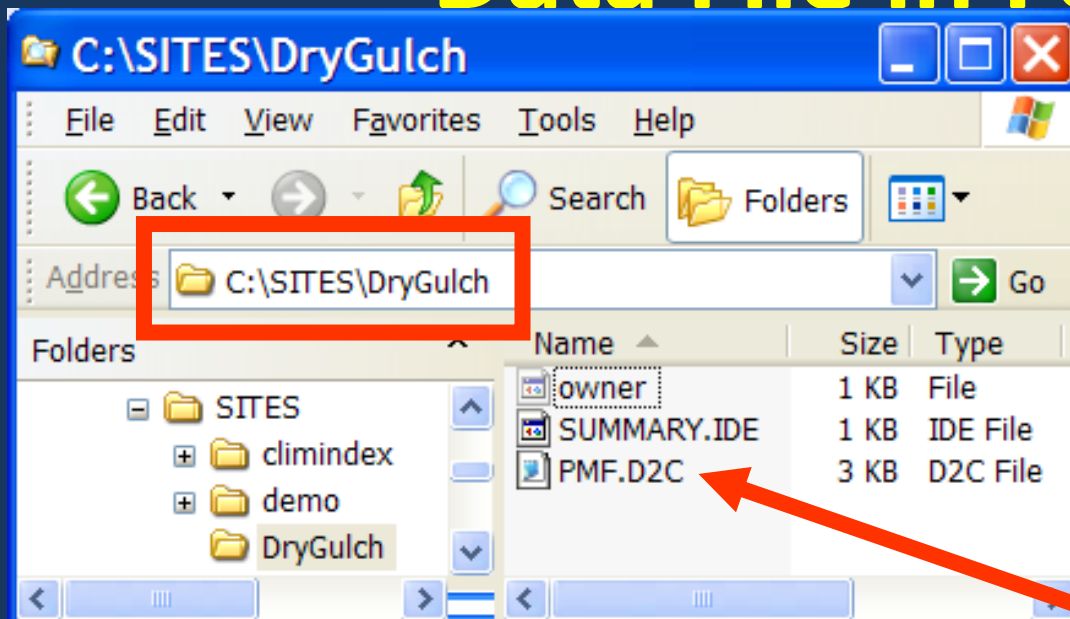

Building a File (Run)

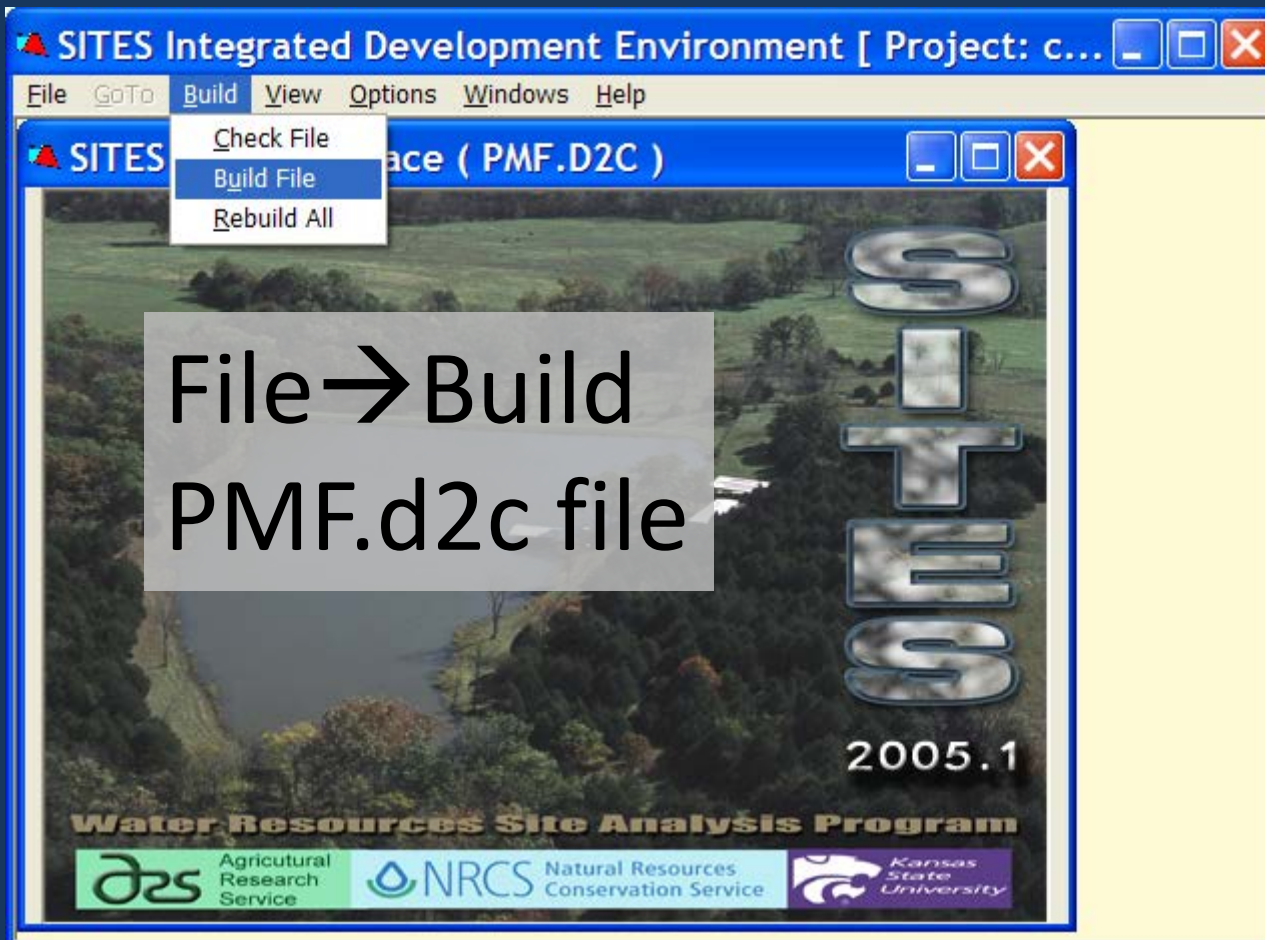

Output Files

The screenshot shows a Windows Explorer window titled "C:\SITES\DryGulch". The address bar shows "C:\SITES\DryGulch" and "SITES Project Folder". The left pane shows a tree view of folders: SITES, climindex, demo, DryGulch (expanded), PMF, Ex2, Ex4, SwSetup, temp, and usda. The right pane shows the contents of the "PMF" folder:

Name	Size	Type
PMF Output Folder		File Folder
BK_SDH_FBH_KKV.D2C	3 KB	D2C File
owner	1 KB	File
PMF.D2C Data File	3 KB	D2C File
PMF.DEC	2 KB	DEC File
PMF.DEM	1 KB	DEM File
PMF.DHY	73 KB	DHY File
PMF.DIS	1 KB	DIS File
PMF.DRG	3 KB	DRG File
PMF.OUT Output File	18 KB	OUT File
SUMMARY.IDE	1 KB	IDE File