



United States
Department of
Agriculture

Natural Resources Conservation Service

Part 650 Engineering Field Handbook National Engineering Handbook

Chapter 12 Springs and Wells

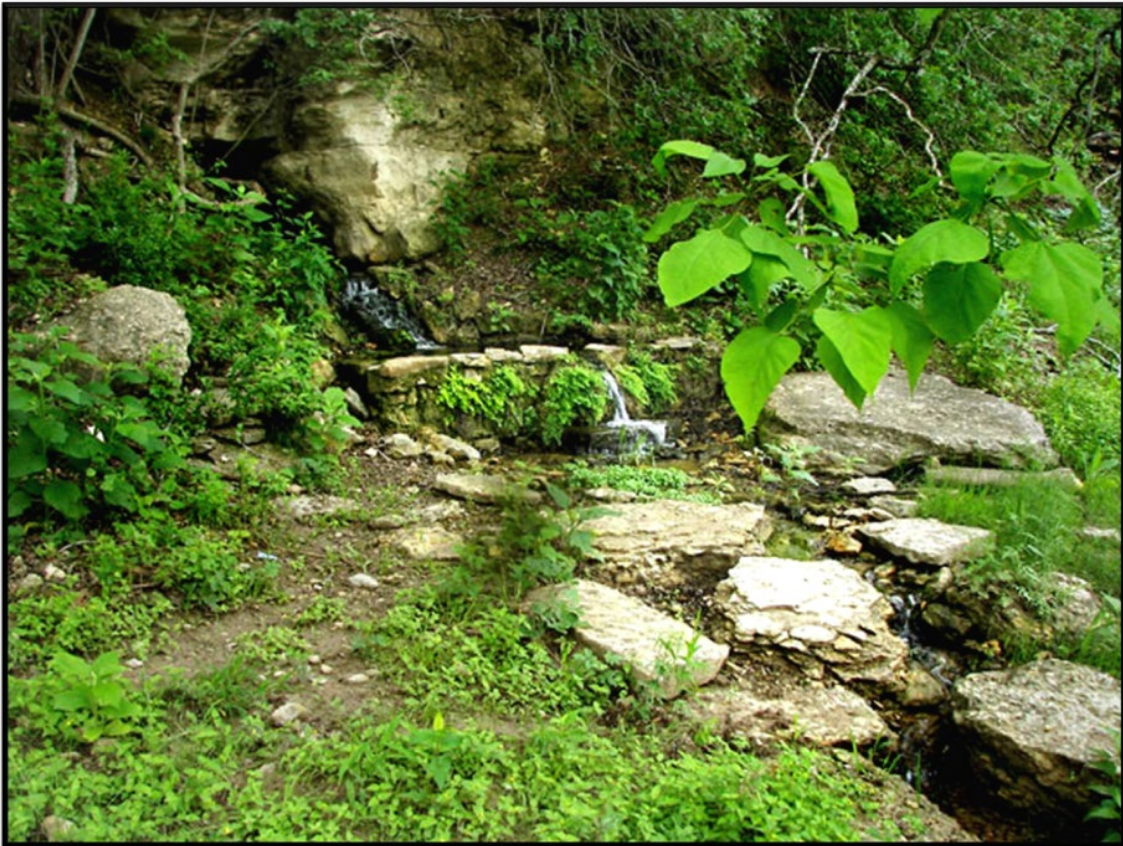

Issued February 2021

In accordance with Federal civil rights law and U.S. Department of Agriculture (USDA) civil rights regulations and policies, the USDA, its Agencies, offices, and employees, and institutions participating in or administering USDA programs are prohibited from discriminating based on race, color, national origin, religion, sex, gender identity (including gender expression), sexual orientation, disability, age, marital status, family/parental status, income derived from a public assistance program, political beliefs, or reprisal or retaliation for prior civil rights activity, in any program or activity conducted or funded by USDA (not all bases apply to all programs). Remedies and complaint filing deadlines vary by program or incident.

Persons with disabilities who require alternative means of communication for program information (e.g., Braille, large print, audiotape, American Sign Language, etc.) should contact the responsible Agency or USDA's TARGET Center at (202) 720-2600 (voice and TTY) or contact USDA through the Federal Relay Service at (800) 877-8339. Additionally, program information may be made available in languages other than English.

To file a program discrimination complaint, complete the USDA Program Discrimination Complaint Form, AD-3027, found online at [How to File a Program Discrimination Complaint](#) and at any USDA office or write a letter addressed to USDA and provide in the letter all of the information requested in the form. To request a copy of the complaint form, call (866) 632-9992. Submit your completed form or letter to USDA by: (1) mail: U.S. Department of Agriculture, Office of the Assistant Secretary for Civil Rights, 1400 Independence Avenue, SW, Washington, D.C. 20250-9410; (2) fax: (202) 690-7442; or (3) email: program.intake@usda.gov.

USDA is an equal opportunity provider, employer, and lender.

Table of Contents

650.1200 Introduction 12.1

- A. General..... 12.1
- B. Purpose..... 12.1
- C. Groundwater Definition 12.1
- D. Groundwater Source Description 12.2
- E. Title 210, National Engineering Handbook (NEH) References 12.2
- F. National Conservation Practice Standard (CPS) References..... 12.2

650.1201 Groundwater 12.2

- A. Aquifers 12.2
- B. Potentiometric Surface 12.2

650.1202 Water Supply Source 12.3

- A. Water-bearing Materials 12.3
- B. Aquifers in the Continental United States 12.4
- C. Effects of Geologic Structure 12.5
- D. Conservation of Groundwater Resources 12.7

650.1203 Springs and Seeps 12.7

- A. Definition..... 12.7
- B. Springs 12.7

C. Seeps 12.8

650.1204 Spring Development and Design 12.11

- A. Introduction..... 12.11
- B. Planning and Investigation 12.11
- C. Removing Obstructions..... 12.11
- D. Collecting Flow..... 12.12
- E. Lowering Outlet Elevation 12.12
- F. Construction Techniques 12.12
- G. Delivering Spring Water by Gravity Flow 12.16
- H. Pumps 12.16

I. Maintenance..... 12.19

650.1205 Wells..... 12.19

- A. Definition..... 12.19
- B. Well Types..... 12.19
- C. Site selection 12.22

| | |
|--|-------|
| D. Hydraulics..... | 12.25 |
| E. Aquifer tests | 12.26 |
| F. Design Planning..... | 12.27 |
| G. Design Capacity..... | 12.29 |
| H. Diameter | 12.31 |
| I. Efficiency | 12.32 |
| J. Cased Section..... | 12.32 |
| K. Intake Section | 12.33 |
| L. Multiple Well Systems | 12.36 |
| M. Construction..... | 12.39 |
| N. Well Development after Installation | 12.40 |
| O. Testing | 12.41 |
| P. Measuring Drawdowns..... | 12.42 |
| Q. Measuring Yield | 12.43 |
| R. Selecting a Pump..... | 12.43 |
| S. Pump Service..... | 12.44 |
| T. Water Testing..... | 12.44 |
| U. Clogging of Intake Section..... | 12.44 |
| V. Well Testing..... | 12.44 |
| W. Well Failures..... | 12.44 |
| X. Applicable State Laws and Groundwater Rights..... | 12.45 |
| Y. Contracts and Specifications | 12.45 |
| Z. Records..... | 12.46 |
| AA. Abandonment..... | 12.47 |
| 650.1206 Definitions..... | 12.47 |
| 650.1207 References | 12.49 |
| Appendix A – Example Problems | 12A.1 |
| A. Example Problem to Estimate Capacity | 12A.1 |
| B. Filter Design Example..... | 12A.1 |
| C. Optimal Drawdown and Yield Estimation Problem | 12A.2 |

Table of Figures

| | |
|---|------|
| Figure 12-1: The Hydrologic Cycle with a Focus on Groundwater | 12.1 |
| Figure 12-2: Artesian Aquifer Flowing at the Ground Surface, Missouri..... | 12.3 |
| Figure 12-3: Principle Aquifers of the United States..... | 12.4 |

Figure 12-4: Groundwater Provinces of the United States..... 12.5

Figure 12-5: Effect of Geologic Structure on Groundwater..... 12.6

Figure 12-6: Depression spring, Seepage or Filtration Type 12.8

Figure 12-7: Typical Contact Spring 12.8

Figure 12-8: Springs in Jointed Sandstone 12.9

Figure 12-9: Springs in Jointed Basalt..... 12.9

Figure 12-10: Springs in Jointed Limestone..... 12.10

Figure 12-11: Artesian Springs at Aquifer Outcrop..... 12.10

Figure 12-12: Spring Development in Stream Channel..... 12.13

Figure 12-13: Spring Collection System 12.14

Figure 12-14: Spring Box and Pipe Arrangement 12.15

Figure 12-15: Hydraulic Ram Cross Section 12.17

Figure 12-16: General Configuration of a hydraulic ram used for stream development 12.17

Figure 12-17: Center-pivot Sprinkler Irrigation Systems Using a Well as a Source of Water,
Idaho 12.20

Figure 12-18: Sand Point Used for a Small Driven Well..... 12.20

Figure 12-19: Water Well Construction Methods and Applications..... 12.23

Figure 12-20: Diagram Showing Groundwater Terminology..... 12.25

Figure 12-21: Typical Irrigation Well in Unconsolidated Materials..... 12.26

Figure 12-22: Documentation of Water Table Well Design 12.28

Figure 12-23: Documentation of Artesian Well Design 12.28

Figure 12-24: Diagram Showing Terms used in the Artesian Aquifer Equation 12.31

Figure 12-25: Changes in Yield with Increase in Well Diameter 12.32

Figure 12-26: Guidance on When to Use a Gravel Pack Table 12.36

Figure 12-27: A Satellite Well Unit of a Multi-well System 12.38

Figure 12-28: Typical Multi-well Manifold System (Pump may be an engine or electric motor)
..... 12.38

Figure 12-29: Sample Layouts for Manifold Pumping Systems..... 12.39

Figure 12-30: Well Interference in an Unconfined Aquifer..... 12.39

Figure 12-31: Cross Section of Developed Well Showing Filter Pack and Well Screen 12.40

Figure 12-32: Relationship between Drawdown and Yield 12.41

Figure 12-33: Airline Measuring Depth to Water Level..... 12.42

Figure 12-34: Water Well Pump Powered by Electric Motor, Washington..... 12.43

Figure 12A-1: Aquifer Materials Sieve Results..... 12A.1

Figure 12A-2: Filter Design Gradation, based on Aquifer Particle size Distribution..... 12A.2

Part 650 – National Engineering Handbook

Chapter 12 – Springs and Wells

650.1200 Introduction

A. General

This chapter contains updates for formatting only. The next amendment to this chapter will include technical updates.

B. Purpose

The purpose of this chapter is to provide conservationists and engineers with some of the fundamentals of planning and developing groundwater resources. For a successful long-lasting water supply from springs or wells, consider and analyze the information provided in this chapter. This chapter describes the nature of groundwater, methods of obtaining it from springs or wells, and the development and maintenance of groundwater recovery systems. One cannot overemphasize the economic importance and the many advantages groundwater has over water from other sources.

C. Groundwater Definition

The term “groundwater” is a simplistic term that encompasses water in the saturated zone beneath the Earth’s surface, water that is under pressure, and the complex movement of groundwater as an integral part of the Earth’s hydrologic cycle, as depicted in figure 12–1.

Figure 12-1: The Hydrologic Cycle with a Focus on Groundwater

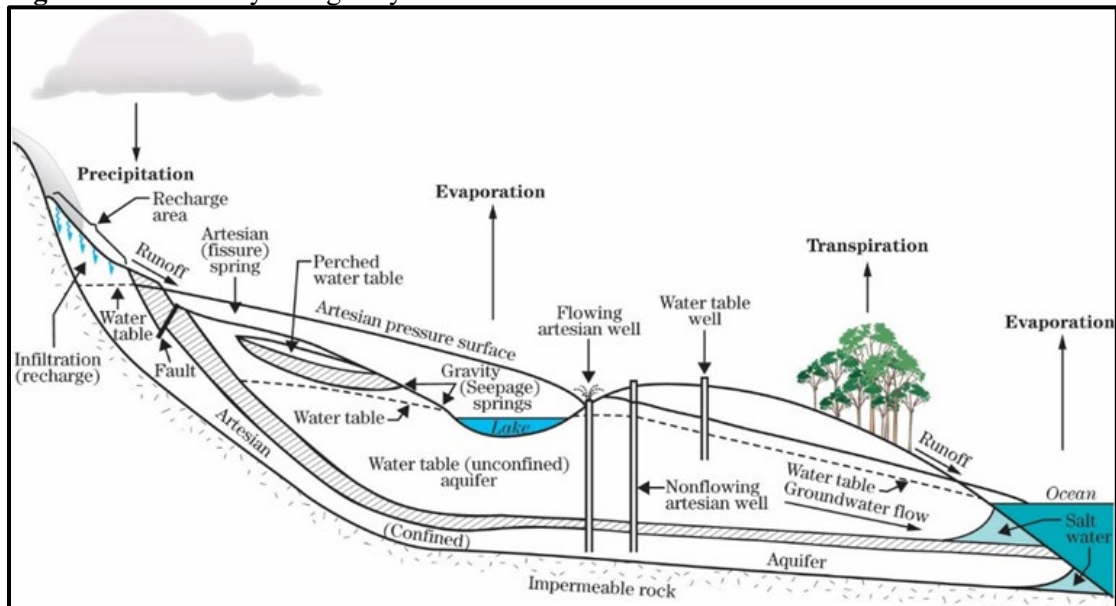

D. Groundwater Source Description

The principal ways of using groundwater are through spring and well developments. A spring is a natural outflow of water from an underground supply to the ground surface. A seep differs from a spring, in having no definite opening. A well (vertical or horizontal) is a hole drilled, dug, or driven into the earth to obtain groundwater.

E. Title 210, National Engineering Handbook (NEH) References

For more detailed information, refer to the following chapters in the USDA NRCS, 210-NEH-631, “Geology”:

- (i) Chapter 30, Groundwater Hydrology and Geology
- (ii) Chapter 31, Groundwater Investigations
- (iii) Chapter 32, Well Design and Spring Development
- (iv) Chapter 33, Groundwater Recharge

F. National Conservation Practice Standard (CPS) References

- (1) Springs - Code 574, Spring Development
- (2) Wells - CPS Code 642, Water Well

650.1201 Groundwater

A. Aquifers

The zone of saturation in the Earth’s crust is groundwater called aquifers. Three types of aquifers are: water table aquifers, confined aquifers, or perched aquifers.

- (i) Water Table Aquifer – The water table aquifer is not confined, is at atmospheric pressure, and may rise or fall in the upper zone of saturation, depending on rate of recharge and rate of withdrawal, drainage, or outflow.
- (ii) Confined Aquifer — In a confined aquifer, an overlying relatively impermeable layer may confine water in the saturation zone, and at a pressure greater than atmospheric. If water in a confined aquifer rises above the containing layer when penetrated, the aquifer is said to be artesian even though water may not freely flow from the well. Many artesian wells do not flow freely at the ground surface like shown in figure 12-2, but the added pressure reduces pumping requirements.
- (iii) Perched Aquifer — Perched aquifers occur in the vadose zone above and not connected to the regional water table. They occur because of an aquiclude or lower barrier of less permeable strata. Perched aquifers may be important local but limited sources of fresh water. Many volcanic islands have perched aquifers, which are important freshwater sources, for example.

B. Potentiometric Surface

The potentiometric surface is the elevation which water will rise in a tube or well that penetrates an aquifer (confined or unconfined).

Figure 12-2: Artesian Aquifer Flowing at the Ground Surface, Missouri



650.1202 Water Supply Source

A. Water-bearing Materials

(1) Important Water-bearing Material Properties

- (i) Porosity – Porosity is an expression of void spaces
- (ii) Permeability — Permeability is an expression of the ability of the earth material to transmit water

(2) Aquifer Components

- (i) Unconsolidated Material — Sands or gravels with high porosity and permeability.
- (ii) Jointed and Permeable Sandstone — Permeability, or the uniformity, compaction, number of interconnected voids (pores), and the frequency of joints, fractures, and bedding plane openings controls the movement of groundwater in sandstone.
- (iii) Limestone — Joints and solution passages controls the movement of groundwater in limestone.
- (iv) Volcanic Related Material — Joints and fractures in volcanic rock, lava tubes, interflow zones, voids in cinder beds, or alluvial deposits (deposited by running water) between lava flows controls the movement of groundwater in this setting.
- (v) Dense Hard Rock — Jointed or fractured zones of dense, hard rock may yield small amounts of groundwater. Joints, fractures, and lineaments stand open in such rock at depths of less than 300 feet. Lineaments can be extensive surface features or a linear topographic feature of regional extent that may reflect crustal structure (e.g., fault lines, aligned volcanoes, and straight stream reaches).

- (vi) Fine-grained Material — Fine-grained (primarily silts and clays) sedimentary formations and sands or gravels with clay fines are relatively impermeable and do not yield appreciable amounts of water to wells. Occasionally, open fractures, joints, or lineaments may yield some water to wells. These materials frequently form confining layers over more permeable materials.

B. Aquifers in the Continental United States

- (1) General information about groundwater and aquifers in the United States is available from the U.S. Geological Survey's (USGS) National Atlas of the United States (USGS 2011). See figure 12-3.
- (2) The USGS has delineated significant groundwater provinces of the United States (figure 12-4) (USGS 1984) (<http://pubs.usgs.gov/wsp/2242/report.pdf>), based on the areal extent of important water-bearing formations. The referenced document also provides a detailed description of the provinces.
- (3) State geological surveys may also have more detailed groundwater maps and other information about groundwater resources.

Figure 12-3: Principle Aquifers of the United States

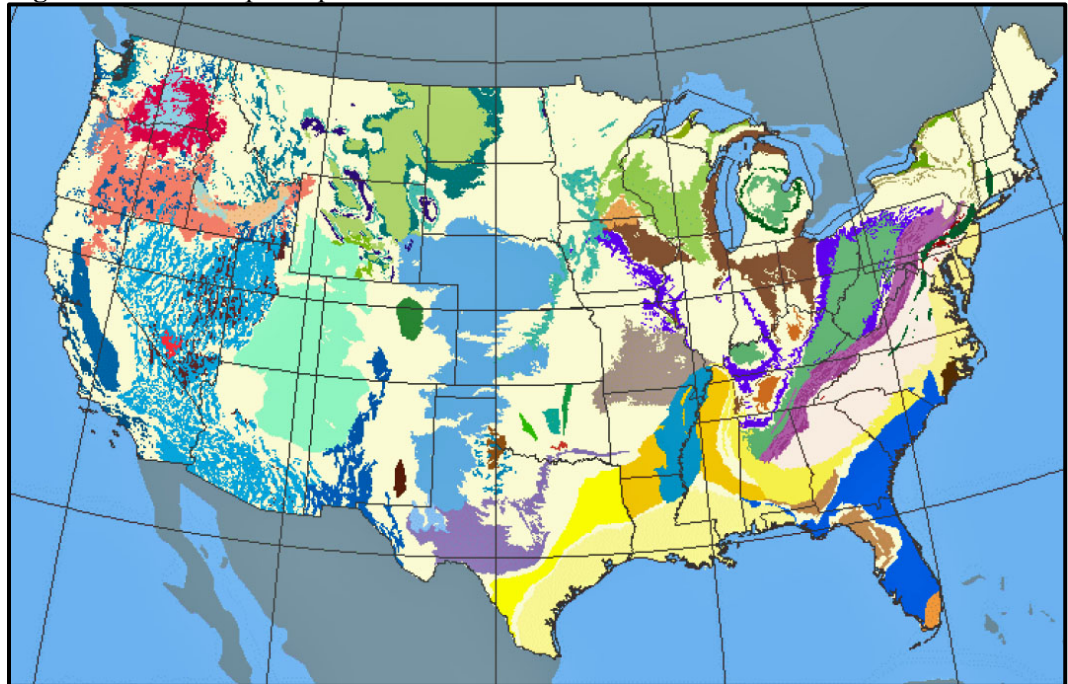
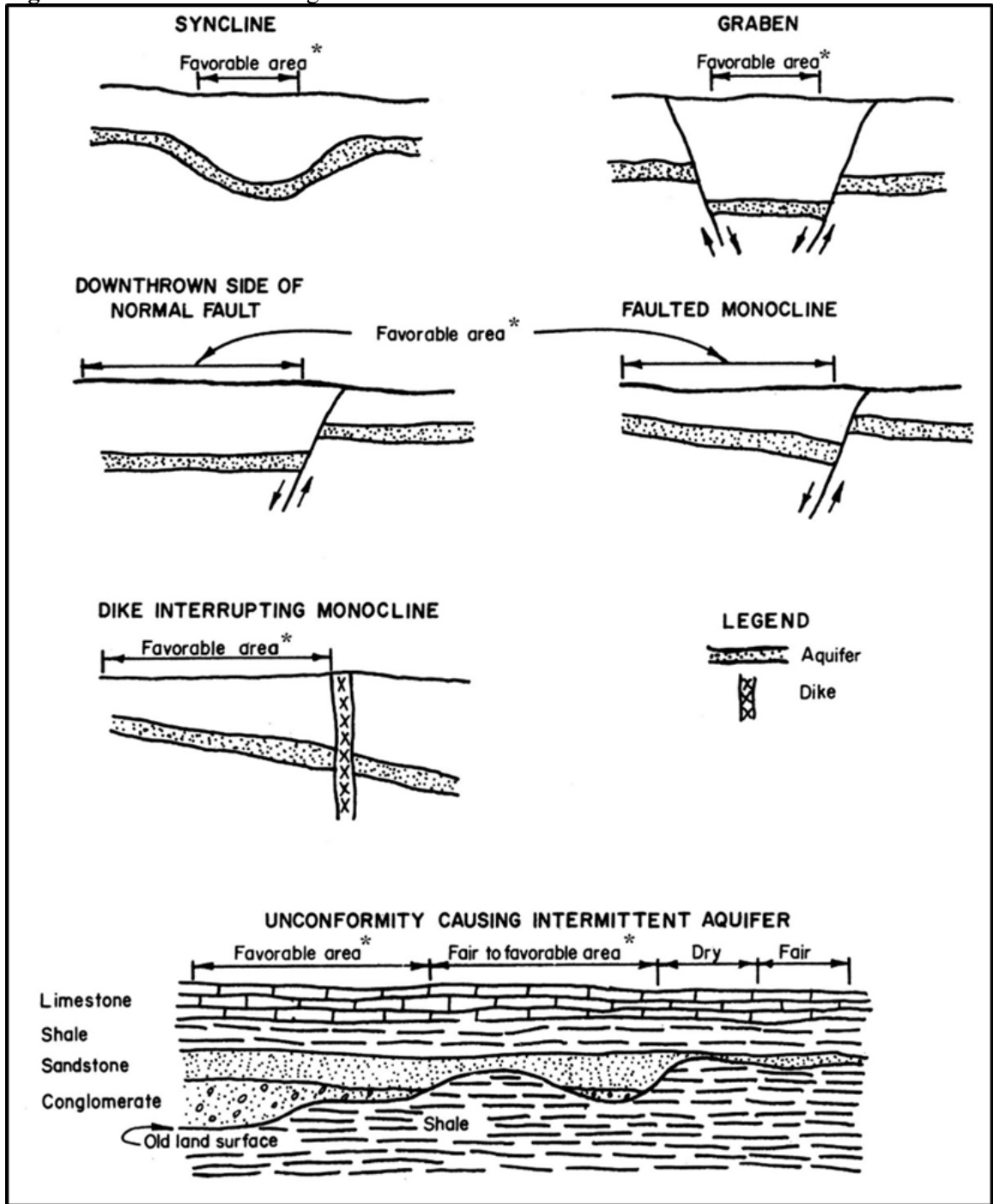

Figure 12-5: Effect of Geologic Structure on Groundwater



D. Conservation of Groundwater Resources

With the expanding use of groundwater resources, planners, developers, and users should recognize the need for conservation. A groundwater conservation plan should consider the following:

- (i) Take in the measures in the design to prevent cross-contamination when a recovery system is composed of groundwater from two separate aquifer systems.
- (ii) Protect groundwater resources around livestock waste confinement facilities.
- (iii) Uncontrolled discharge from a free-flowing artesian aquifer may waste large amounts of groundwater
- (iv) The conservation program for groundwater development should analyze the amount that is economical to withdraw from the aquifer, the purpose of use, and the expected amount of recharge.
- (v) Locating a new well too close to other operating systems may lower the water table and destroy the existing systems.

650.1203 Springs and Seeps

A. Definition

A spring or seep is a place where water from an aquifer discharges naturally into a surface water body or onto the land surface. Flow is controlled by either gravity or hydraulic pressure (artesian).

B. Springs

Spring flows may vary considerably throughout the year, especially when originating from an unconfined aquifer. Spring flow variations are due to the rise and fall of water in a water table aquifer, rate of recharge, or the variation of pressure in an artesian aquifer.

(i) Gravity Springs

- Gravity springs result where water moves from the water table aquifer through permeable materials to the land surface, or where the land surface intersects the water table. Gravity springs are normally low-yielding sources of groundwater. However, they may supply enough water for individual household or livestock needs.
- Gravity springs are of three principal types: depression springs, contact springs, and fracture or tubular springs.
 - Depression Spring — When the land surface intercepts the water table in permeable material, it forms a depression spring. Figure 12–6 shows the geologic structure for a depression spring.
 - Contact Spring — When a layer of impervious material; for example, the outcrop of a perched water table, deflects groundwater movement laterally to the surface, it forms a contact spring. Figure 12–7 shows the geologic structures for contact springs.
 - Fracture or Tubular Springs — When water emerges from fractures or joints in rock, from solution channels in limestone or gypsum, or from natural tunnels in volcanic rock, it forms a fracture or tubular spring. Figures 12–8 through 12–10 show the geologic structures for fracture or tubular springs.

- (ii) Artesian Springs — When relatively impervious strata confines water introduced to permeable strata exposed near the surface at higher elevations, the confined water is under artesian pressure. See (figure 12-11). Fault rupture of an upper confining layer or aquifer discharge to a lower topographic area may cause springs. The flow from these springs depends on the difference in the recharge and discharge elevations of the aquifer and the size of the openings transmitting the water. Artesian springs can be sensitive to pumping of nearby wells.

C. Seeps

Develop a seep like a spring, capturing and funneling the water to a point of use. A seep does not have a defined outlet like a spring, but zones where seepage emerges.

Figure 12-6: Depression spring, Seepage or Filtration Type

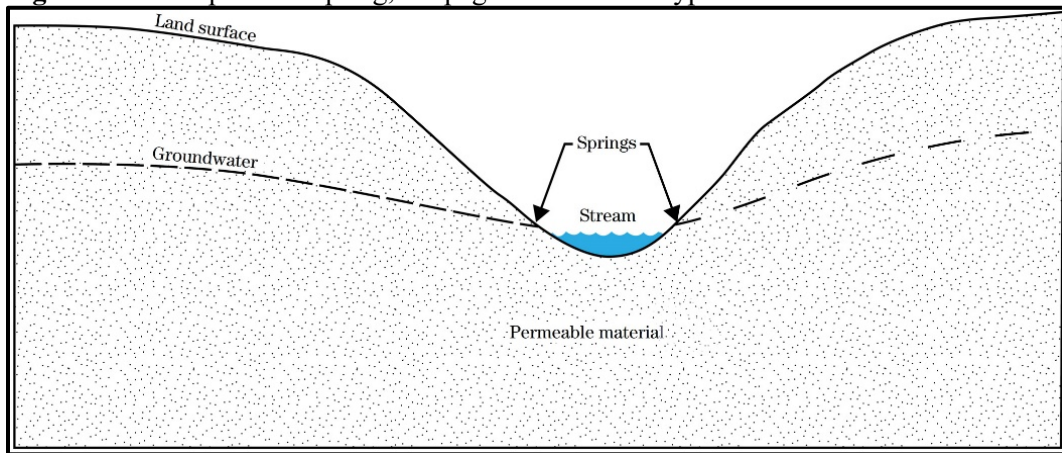

Figure 12-7: Typical Contact Spring

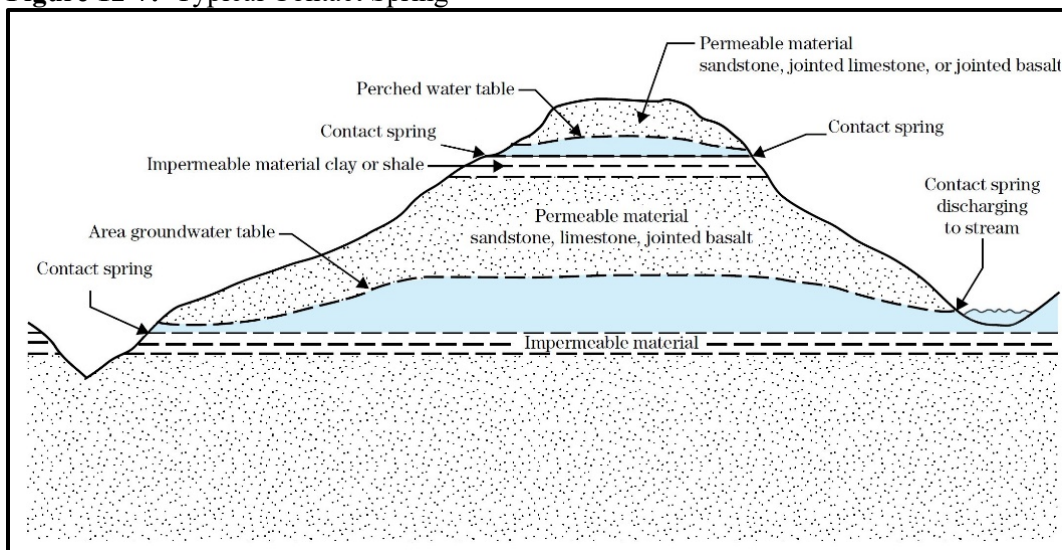

Figure 12-8: Springs in Jointed Sandstone

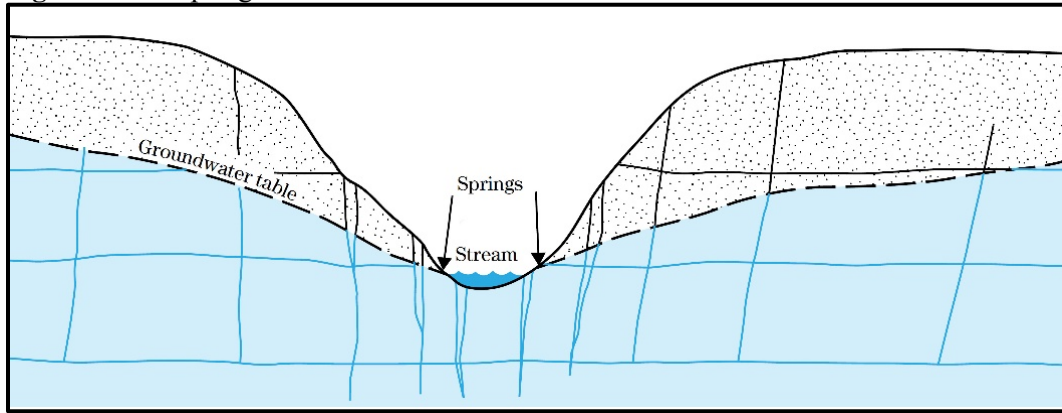

Figure 12-9: Springs in Jointed Basalt

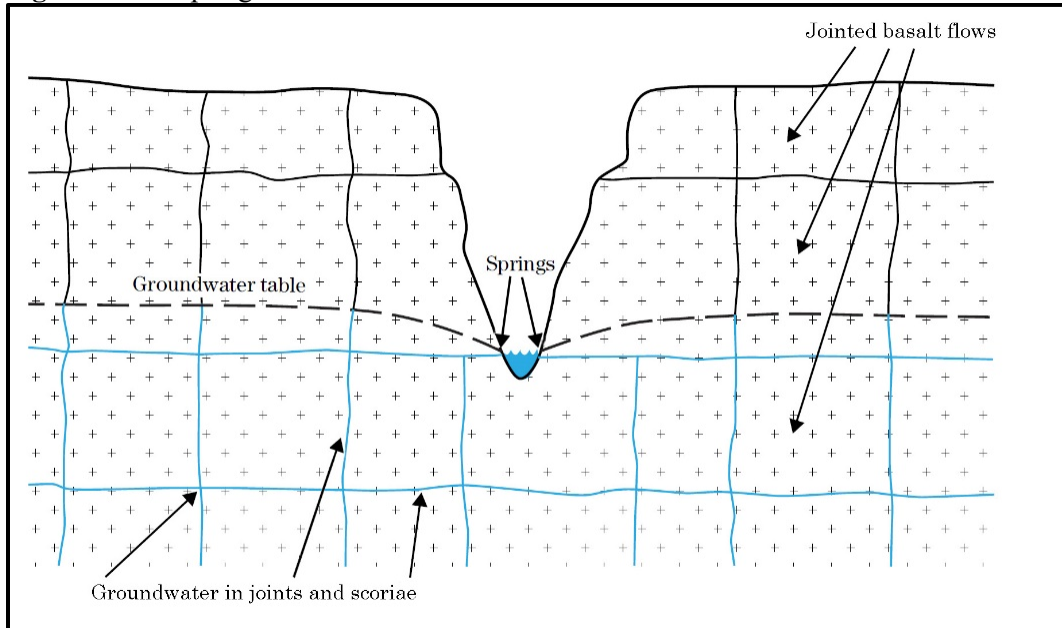

Figure 12-10: Springs in Jointed Limestone

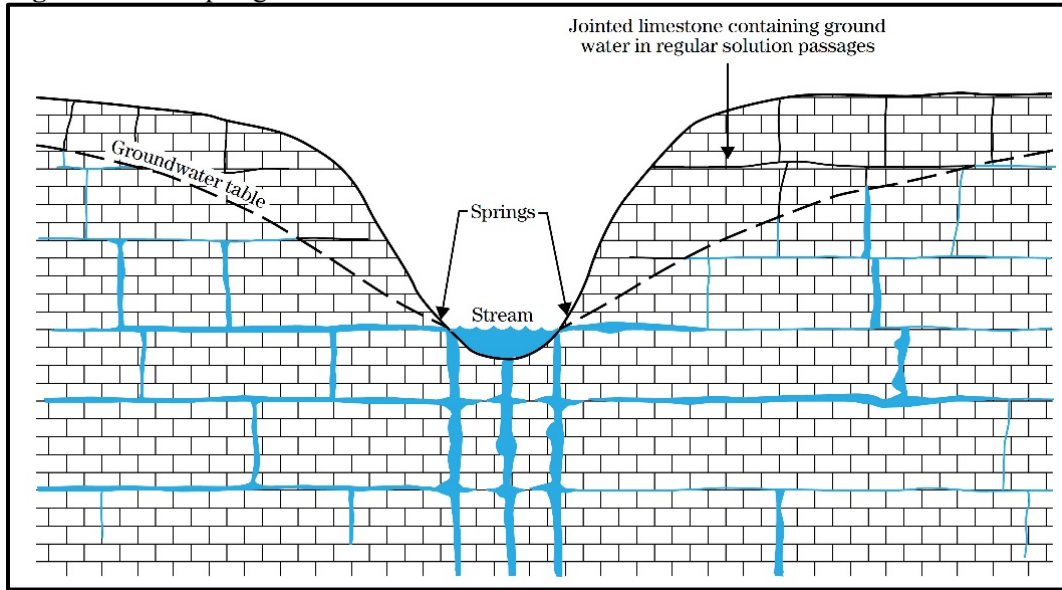
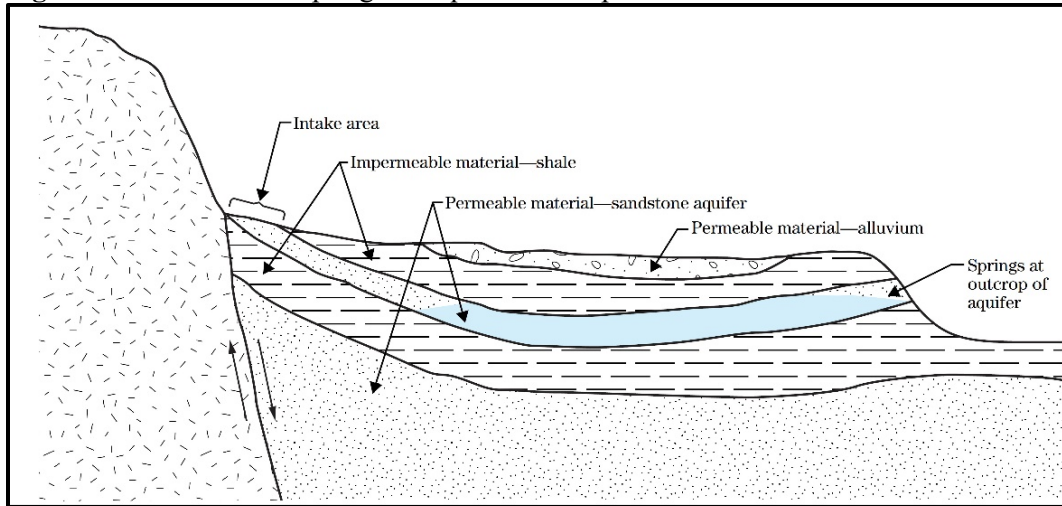

Figure 12-11: Artesian Springs at Aquifer Outcrop



650.1204 Spring Development and Design

A. Introduction

In developing springs or seeps, it is necessary to select a spring that can provide the required quantity and/or quality of water for the intended use, protect it so that it can be used without excessive maintenance, and determine that it will meet all NRCS requirements. Collect existing information to determine feasibility and potential for development for water supply, such as:

- (i) Existing spring and well locations and yields
- (ii) Current hydrologic conditions (precipitation and departure from normal)
- (iii) USGS and State geological survey investigative reports
- (iv) Copies of well drillers' logs for wells in the vicinity or in aquifers of interest
- (v) Interviews with well drillers who have done work in the area
- (vi) County soil survey report and interpretation data, and general description of geologic conditions
- (vii) Map showing groundwater development sites and including the geologic situation of each site
- (viii) Groundwater contour maps or structural contour maps of known aquifers
- (ix) Geology reports from previous investigations

B. Planning and Investigation

- (1) Spring flow may vary significantly throughout the year. The investigation should determine the range of flows and the nature of the water-bearing material and the hydrogeologic conditions that create the spring. The assessment should determine if the spring development will affect ecological functions. Acquire water rights and other necessary permits before spring development. Also, conduct a wetland determination and cultural resources assessment.
- (2) Prepare a plan with the user before making design and construction decisions, if the investigation shows that the user could develop a spring site. In relation to the direction of groundwater flow, identify possible sources of contamination from barns, feedlots, septic fields, and other zones of saturation.
- (3) If the design requires more volume, methods of developing gravity springs normally involves removal of obstructions, collection of flow, and drainage of more of the water-bearing formation.
- (4) Develop an artesian spring by any of the methods for gravity springs, as well as by lowering the outlet elevation.

C. Removing Obstructions

- (1) Deposits of fine-grained materials (sand, silt, or clay) brought to the outlet by groundwater can obstruct spring flow, as can slope-wash materials have deposited on the outlet. Vegetation growing in or around the outlet can obstruct flow and consume water. Removing obstructions usually adds appreciably to the spring flow.
- (2) Use a filter or sump if spring water carries sediment to the opening. Design for the sump to be located below the spring so that the sediment will not build up over the outlet between periodic cleanings. Also design to facilitate cleaning by sluicing if possible, and diversions to carry harmful surface drainage away from the spring area. When planning a design for the collection of several small flows, use covered galleries or drains to avoid the need to clean and maintain diversions.

- (3) The transpiration of plants can substantially reduce the flow of small springs. Remove plants mechanically or by controlled use of herbicides; exercising care using either method.
 - (i) Herbicides could contaminate the spring
 - (ii) When using mechanical removal, establish suitable vegetation to prevent exposing large areas of bare, erodible earth, to reduce the impairment of the spring opening or downstream areas by sediment.

D. Collecting Flow

- (1) Collecting the flow from several openings or seepage areas from an outcrop of water-bearing material may be the only practical method for development. Clean individual openings if water flows from fractures and collected in a perforated pipeline or gravel-filled ditch (French drain) graded to discharge in a central sump or spring box.
- (2) In collecting water seeping from permeable material, the ditch or tunnel should expose the necessary length and thickness of the water-bearing zones. The excavation must extend far enough below the water-bearing zones to ensure gravity collection.
- (3) Excavation may increase the flow of depression and contact springs to drain additional portions of the aquifer. Such excavation can be either by ditches or tunnels, depending on the topography at the spring, and the characteristics of the water-bearing and underlying materials.
- (4) If the spring is on gently sloping or nearly level terrain, a ditch along the outcrop of the water-bearing material is usually the most economical method of collection. Dig a ditch to intercept as much of the water-bearing zone as practical.

E. Lowering Outlet Elevation

This method can improve the flow of springs supplied by an extensive system of channels in rock or by a large volume of permeable water-bearing material, as in some artesian springs. Lowering the outlet elevation increases the head of water available to increase flow at the spring. If the available volume is great, lowering the outlet elevation may produce a substantial and long-lasting increase in flow, however, with limited flow, the increase in flow may be only temporary. Prior to lowering the outlet, characterize the supply source.

F. Construction Techniques

- (1) Previous local experience may be the single most important factor in developing a spring. The method of development chosen should be based on characteristics of the spring, such as topography, nature of the water-bearing material, type of spring opening, volume of flow, and seasonal or yearly variations in flow.
- (2) NRCS does not recommend the use of explosives in spring development. The shattering and dislocation of rock from blasting may cause the existing flow to cease or to move to another location.
- (3) Spring Box
 - (i) A spring box and pipeline are the most satisfactory means of delivering water to the point of use. Design and locate the spring box so that water does not pond over the spring openings. Ponding above the spring openings reduces spring flow and may cause seeps to change their path of flow. See figures 12-12 through 12-14 for sketches of a typical spring collection system, spring box, and pipe arrangement. The collection system shown is suitable for developing a seepage or filtration spring (figure 12-6) or a contact spring (figure 12-7).

- (ii) Construct a spring box in the apex of the V-shaped headwall as shown in figure 12-12. A spring box provides a settling basin for sediment removal and facilitates maintenance of the spring. Use a spring box with a collector system as shown, the upper wall should have openings located so that all the water collected can enter the box.

Figure 12-12: Spring Development in Stream Channel

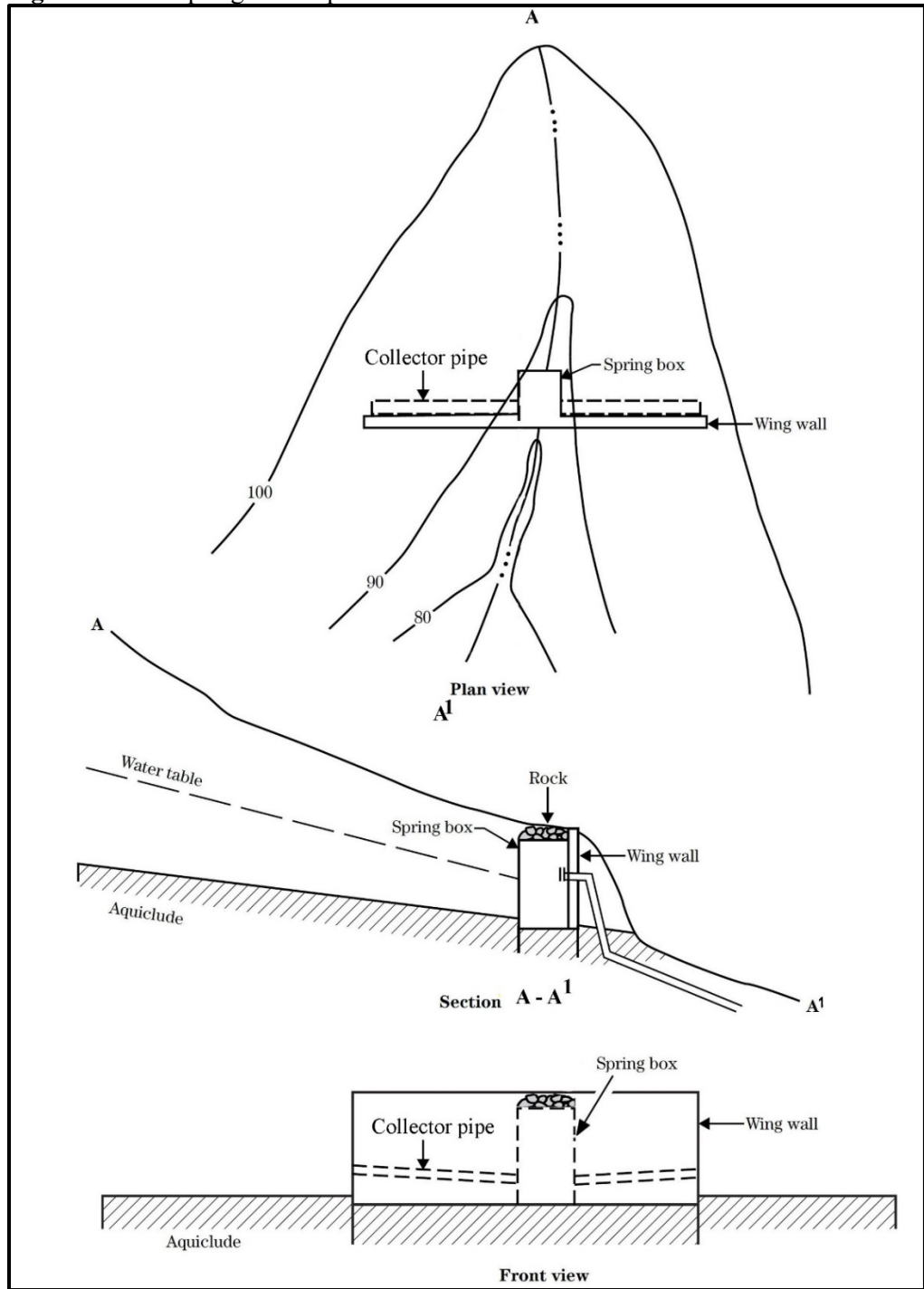

- (iii) Construct spring boxes of concrete, sections of galvanized metal or concrete pipe, HDPE pipe, or other prefabricated materials. Make wooden spring boxes of redwood or treated lumber, if permitted for the intended use. Omit the upper wall of the box for springs not requiring a collector system. The spring box should have a tight-fitting cover. Cover the entire development with earth to a depth that prevents freezing, revegetate the disturbed area, and protect from livestock, wildlife, or vehicular traffic (figures 12-13 and 12-14).

Figure 12-13: Spring Collection System

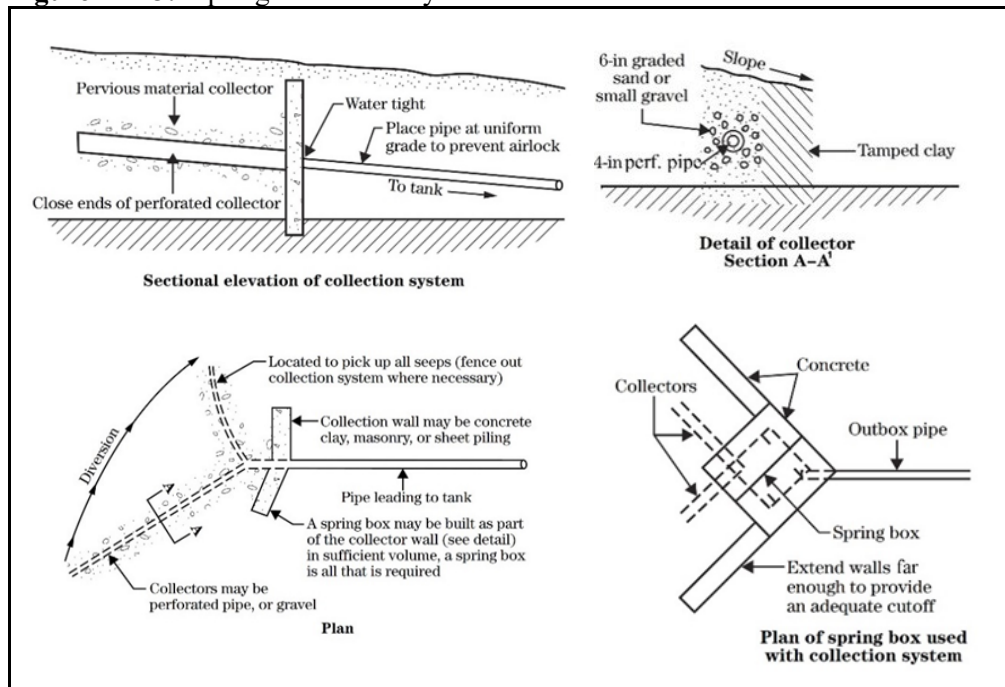
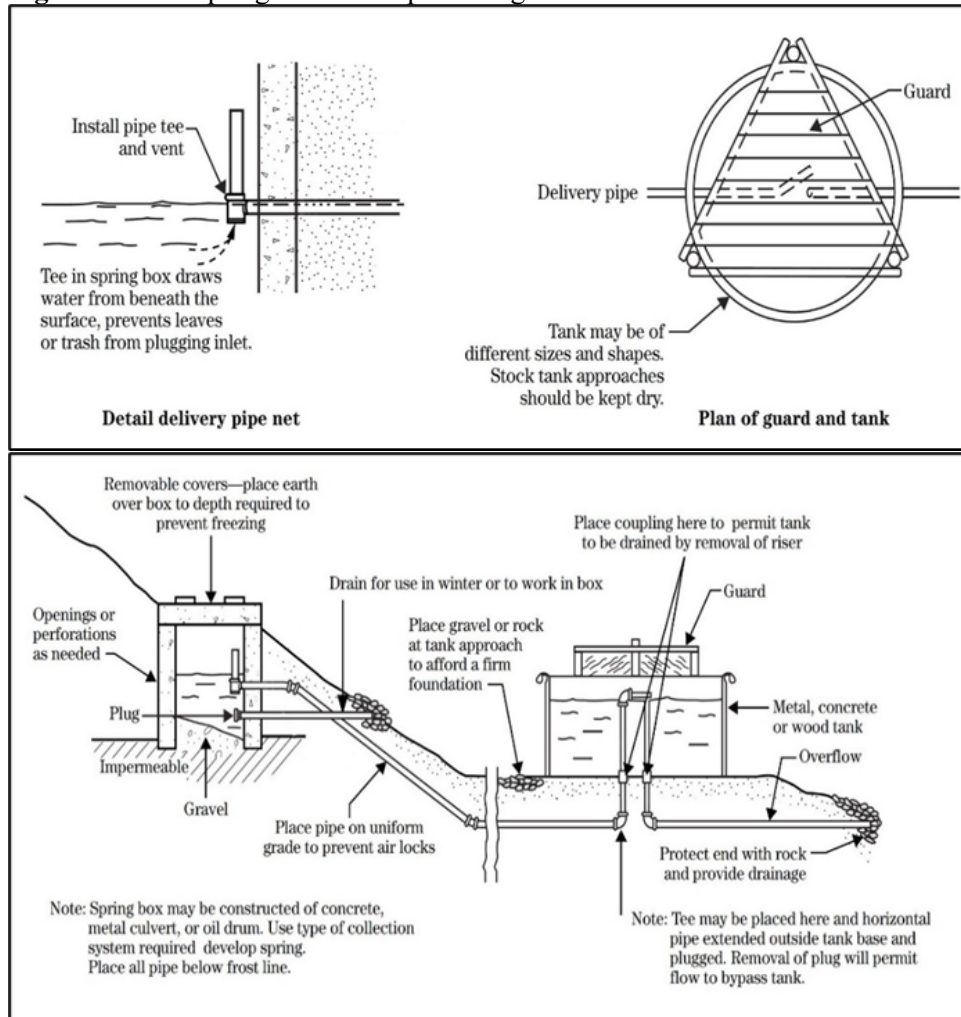

Figure 12-14: Spring Box and Pipe Arrangement



(4) Collector

The collector can consist of perforated pipe laid in graded small gravel or graded sand (figure 12-13), or it can be a ditch backfilled with graded, small gravel or graded sand. Conduct a hydraulic analysis to properly size pipes. When installing a collector in permeable material, construct a cutoff wall of clay, concrete, sheet piling, or other impervious material in the downhill side of the trench. The cutoff should extend down to impervious material to intercept the water and cause it to flow to the point of collection. Under some conditions, drive sand points into saturated material to serve as collectors. Construct the headwall or cutoff as a large V with the apex downhill and the wingwalls extending into the hill to prevent water from escaping. Use 4- to 6-inch thick concrete walls, masonry, sheet piling, plastic, or clay for the headwall, which should extend deep enough to prevent underflow.

(5) Protection

Springs are frequently at locations susceptible to flooding. Design the spring appurtenant structures to permit use without continual maintenance, use diversions if needed. Develop the spring so that flood flows passing over the top do not cause damage. A concrete retaining wall, or wing-wall, properly constructed and located prevents channel degradation and dewatering of the spring aquifer. A spring box with a steel or concrete lid placed below the top of the concrete wing-wall and protected by a debris basin of rock and gravel is adequate flood protection. Extend the pipeline far enough down the valley to avoid flooding of the watering tank. See figure 12-12 for this type of development.

G. Delivering Spring Water by Gravity Flow

(1) An important part of the spring development is the arrangement of the delivery and overflow pipe layout (figure 12-14). Pipelines can be of plastic, copper, or galvanized iron. When you use water for human consumption, Meet state health department requirements for material and installation.

(2) Pipe Design

- (i) Grade Considerations — Lay pipe on a straight, uniform grade, since high spots create air locks that may stop the flow or reduce its velocity
- Use a 1.25 inch inside diameter (ID) pipe at minimum where the grade is over 1 percent.
 - Use 1.50-inch ID pipe at minimum where the grade is between 0.5 percent and 1.0 percent. Grades under 0.5 percent require a 2.0-inch-minimum-diameter pipe.
 - Do not design for grades less than 0.2 percent.

(ii) If pipe of recommended size cannot handle the flow, increase the size or provide an overflow.

(iii) Lay pipe below the frost line and covered to prevent freezing.

(iv) Install vents to improve flow in long delivery lines or at major changes in grade.

(v) Cleaning may be made easier by placing “Ts” or “Ys” with plugs at strategic points in the pipelines. See CPS Code 516, Livestock Pipeline.

(3) Place spring box discharge pipe invert at least 6 inches above the floor to provide a sediment trap. Make a watertight connection should be where the pipe leaves the spring box or goes through the cutoff wall. Install a tee and vent pipe on the pipe within the spring box to reduce plugging by leaves or trash or screen the pipe entrance.

(4) Water tank connection –

(i) Bring the pipe under the tank and vertically through the bottom if using the tank during freezing weather.

(ii) The inlet and outlet pipes should be close together near the center of the tank

(iii) Water may freeze around the edge of the tank, but it will tend to stay open at the center. Figure 12–14 shows a good method of bringing the delivery pipe into the tank and bypassing the flow.

H. Pumps

(1) Use a pump to deliver the water supply if the outlet of the spring is lower than the point of use. Refer to the NRCS Energy Self Assessment Web site for guidance on selection and design of pumps and energy sources (<http://www.ruralenergy.wisc.edu/default.aspx>).

(2) Hydraulic rams

- (i) A hydraulic ram is an automatic pump operated by waterpower. It uses the power developed by the surge of a quantity of falling water to force a much lesser amount of water to an elevation above the source of supply. Figure 12–15 shows a typical hydraulic ram in cross section, and figure 12–16 shows the general configuration of a hydraulic ram used for stream development.

Figure 12-15: Hydraulic Ram Cross Section

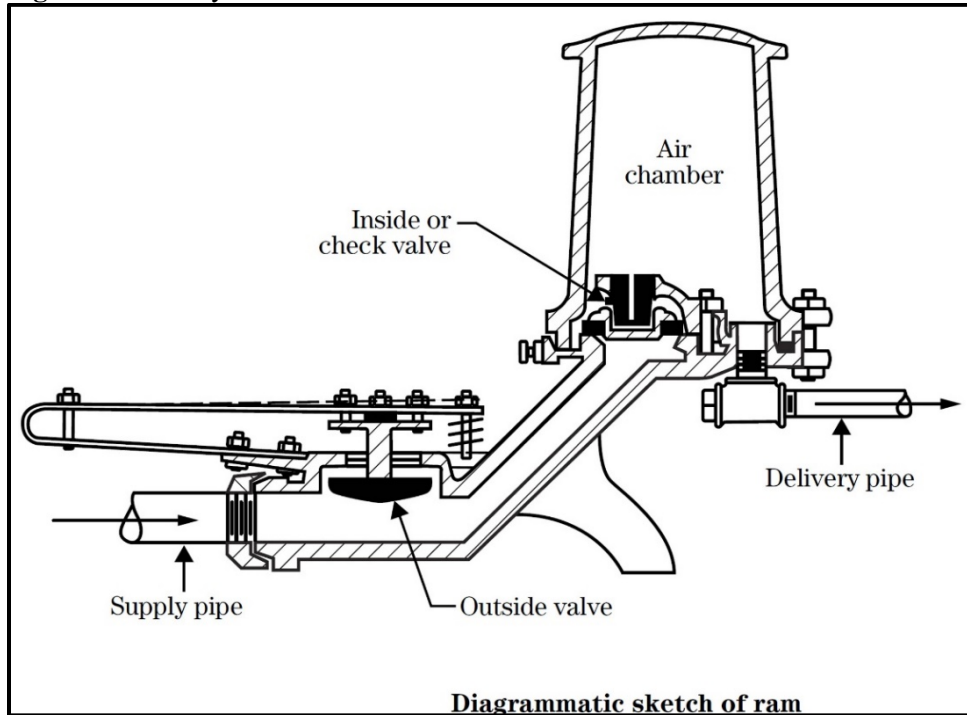
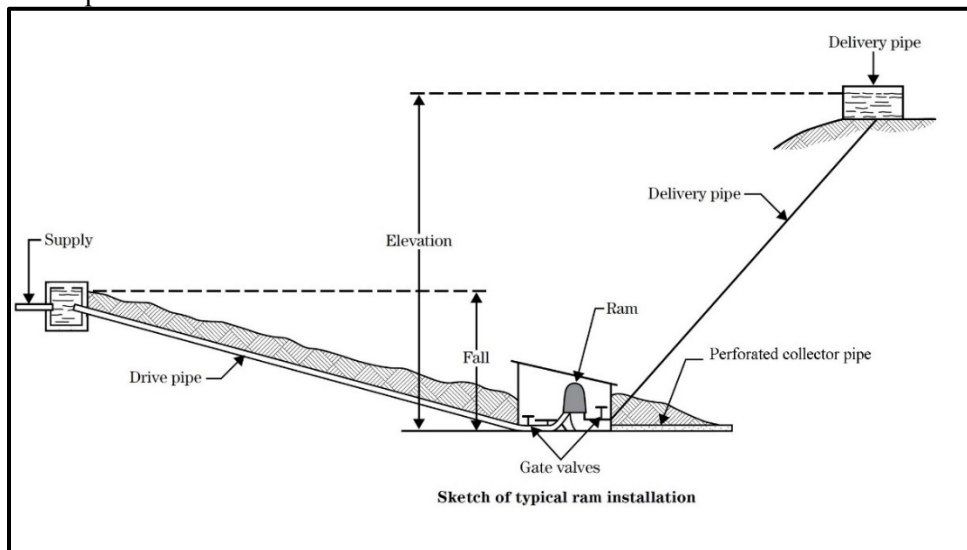

Figure 12-16: General Configuration of a hydraulic ram used for stream development



- (ii) The change in elevation between the water supply and the ram and the quantity of available water determines the water volume a ram can pump. For limited water supply, select a ram that will operate with the minimum quantity of available water. If the water supply is ample, the ram size is governed by the quantity of water needed daily.
- (iii) Manufacturers build rams that operate successfully on flows of 1.5 gallons per minute or more with at least 2 feet of head.
- (iv) Estimate the number of gallons of water delivered per minute to a given point with the following formula:

$$D = \frac{VFe}{E}$$

where: D = volume in gallons per minute (gpm) that the ram will deliver

V = water supply available in (gpm)

F = fall (feet) between the water supply and the ram

E = lift in vertical elevation (feet) of water above the ram

e = ram efficiency (use 0.6 in the absence of specific data)

- (v) To determine if a ram is practical, collect the following information:
 - Number of gallons per minute that the spring, artesian well, or stream, will deliver
 - Number of gallons per day desired from the ram
 - Elevation, in feet, to which water is to be raised above the ram
 - Pipeline distance, in feet, from the ram to the point of discharge
 - Pipeline distance, in feet, from the source of water to the ram
- (3) Internal combustion engines
- (i) Expect that the rated power of internal combustion engines to greatly exceed the power to produce on a sustained basis. Consider the kind of fuel, accessories, and cooling system used, as well as air temperature and altitude in selecting internal combustion engines. The fuel may be gasoline, kerosene, diesel oil, propane, butane, or natural gas. The cooling system may use water or air.
 - (ii) Because altitude and air temperature affect power output, and engine ratings are based on performance at sea level and a temperature of 60 degrees Fahrenheit, make corrections for most irrigation pumping installations. General rules for correcting for elevation and temperature are reduce the continuous load rating 3 percent for every 1,000 feet above sea level and reduce the continuous load rating 1 percent for every 10 degrees above 60 degrees Fahrenheit.
 - (iii) Further reduce the rated power 5 to 10 percent for consumption by accessories (fan, generator, water pump) and 15 to 20 percent for continuous service.
 - (iv) Air quality and energy considerations—Where possible, use renewable energy or electrical power to run pumps in lieu of internal combustion engines to reduce pollution and operating costs.

I. Maintenance

With periodic maintenance, a developed spring will provide good quality water for many years. Springs usually become contaminated when barnyards, sewers, septic tanks, cesspools, or other sources of pollution are located upstream in the recharge area. In very permeable formations (gravels, limestone, basalt, etc.), however, water-bearing channels through sinkholes or other large openings may carry contaminated material in the groundwater for long distances. These precautionary measures help to ensure consistent high quality spring water:

- (i) Test the water quality of a spring prior to development. Install a diversion uphill from the site to intercept surface-water runoff and carry it to a safe outlet.
- (ii) Build a fence to exclude livestock from the surface-water drainage system at all points uphill from the spring.
- (iii) Provide access to the tank for maintenance.
- (iv) Periodically check the spring water for contamination. A marked increase in turbidity or flow after a rainstorm is a good indication that surface runoff is reaching the spring.
- (v) Disinfect spring encasements by a procedure like that used for dug wells. If the water pressure is low enough that water does not rise to the top of the encasement, hold disinfectant for 24 hours. For continuous flow, introduce disinfectant continuously for as long as practicable or per State or local requirements.
- (vi) Continually check the trough for algae buildup, mudholes, and animal damage. Make necessary repairs or adjustments. Methods to control algae buildup include the use of chemicals (e.g., copper sulfate or chlorine bleach), the use and quantity of which depends on the intended water use or ultrasonic methods.

650.1205 Wells

A. Definition

A well to extract groundwater consists of a hole, with or without a supporting casing, extending from the ground surface to or into water-bearing earth materials. When properly constructed and developed, it will permit extraction of groundwater. If the aquifer is artesian, pumping requirements are less or precluded if enough flow is at the ground surface.

- B. Well Types — Well types are dug, driven, or drilled, Depending on their intended depth, the nature of the earth materials, the rate at which water will be removed, and the depth to the groundwater table or the elevation of the piezometric surface for artesian conditions, installation methods are dug, driven, or drilled. Figure 12-17 shows a traveling center-pivot irrigation system with a well as the water supply source.

Figure 12-17: Center-pivot Sprinkler Irrigation Systems Using a Well as a Source of Water, Idaho



- (1) Dug or Open Pit Well – Excavated well by hand into a shallow water-bearing stratum. Such wells are prone to surface water contamination.
- (2) Driven Well — Forced pipe in the ground penetrating the water-bearing stratum. Limit this type of construction to shallow depths, usually less than 50 feet. Driven well construction methods include:
 - (i) Driven pipe fitted with a sand point into the water-bearing formation (figure 12–18). Remove earth material from the pipe by a sand bucket or pump, or a hydraulic jet to remove material from the end of the pipe. For a single pumping unit supplied by multiple wells or where artesian pressure occurs, use this type of construction.
 - (ii) “Direct push” techniques
- (3) Jetted Well – High pressure water delivered through piping. Rods driven through the hydraulic erosion of the earth material, flushing the material up to the surface. The drive bit combined with the jetting action breaks up hard soils or rock formations.

Figure 12-18: Sand Point Used for a Small Driven Well

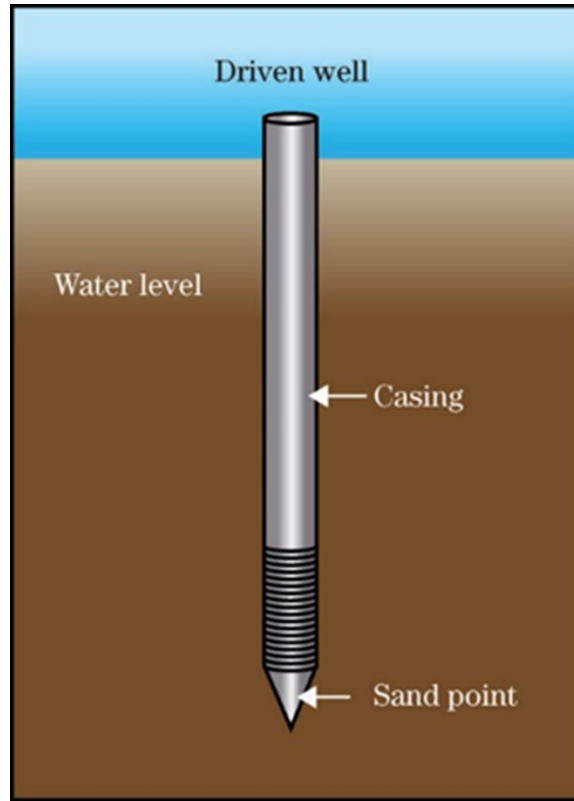

- (4) Drilled Well – Drill to install a well through any material and to great depths. Many types of drilling rigs are, in general, used:
- (i) Rotary auger rig uses a cutting bit and receptacle (bucket cylinder or spiral) attached to a drill stem. Use this equipment is for exploration wells of shallow depth and small diameter.
 - (ii) Cable tool rig or “spudder” uses a weighted bit attached to a flexible cable for breaking the material loose and a bailing bucket for removing the loose material from the well. Use this equipment for drilling 3- to 24-inch diameter wells less than 1,500 feet deep.
 - (iii) Hydraulic rotary rig uses a bit attached to a hollow drill stem. Forced water through the drill stem floats and loosens material out of the well. For drilling through unstable strata, this equipment relies on drilling fluid (mud) to stabilize these sections until the drilling is complete and the casing installed.
 - (iv) Reverse hydraulic rotary rig introduces water at the top of the well and pumps it out through the drill stem, relying on the weight of the water column to hold unstable strata open.
 - (v) Air rotary rig replaces mud with compressed air and are suitable for drilling through hard rock.
 - (vi) Sonic (vibratory) drill rig is a large hydraulic rotary rig that cuts through rock with a combination of cutting and high frequency resonant vibrations. This technology also works well in unconsolidated materials and reduces drill cuttings, drilling time, and often minimizes the disruption of bedding, lamina, and material structure. It also reduces sampling time and enables rapid continuous sampling where needed.

- (vii) The table in figure 12-19 lists various methods of constructing a well and their appropriate application.

C. Site selection

- (1) The following elements are essential to maximize the potential yield of a site and to document the well's planned use and expected yield requirements. It is best to determine whether these elements are present before deciding to drill a well.
 - (i) A study of the water well successes and failures in the area, including location maps, history, and records of wells
 - (ii) Geologic maps and groundwater availability studies
 - (iii) History of known contaminants and spills and their locations and potential hydraulic connections relative to the proposed well location
 - (iv) An adequate and dependable water source
 - (v) Enough underground reservoir space
 - (vi) A structure or conditions that act to retain water
- (2) The geologic investigation should always include a review of existing information on groundwater. Take the following steps after acquiring the information:
 - (i) Step 1. Prepare a base map or obtain aerial photographs of the area. The map or photograph should be to a scale of at least 4 inches = one mile (1:15,840).
 - (ii) Step 2. Interview owners of wells in the area.
 - (iii) Step 3. Interview drillers who have worked in the area.
 - (iv) Step 4. Study well logs and notes of other agencies or water specialists knowledgeable about the area.
 - (v) Step 5. Plot the information acquired on a base map or aerial photograph.
 - (vi) Step 6. Evaluate the chances for obtaining the desired yield and water quality.
- (3) Prepare subsurface investigation plan if you must obtain additional information and include:
 - (i) The location, depth, and number of test holes
 - (ii) Type of drilling rig
 - (iii) Type of sampling and logs requirements
 - (iv) Remote sensing tests, using electrical resistivity, conductivity, and seismic methods
 - (v) Identification of geologic characteristics
 - (vi) Obtain the following information during test drilling:
 - General information
 - Start and completion date
 - Name of individual recording drilling data
 - Location of hole (georeferenced, include map)
 - Drilling method with type of bit, sampling method, mud or fluid type
 - Total depth
 - Name, title, and address of person responsible for the water well
 - Description of rock characteristics of each stratum
 - Thickness and depth of each stratum
 - Drilling characteristics—drilling hard, smooth, fast; bit bounce; mud loss; and bit drop
 - Time used in drilling each interval
 - Types of downhole logging
 - Selected drill cutting and water samples

Figure 12-19: Water Well Construction Methods and Applications

| Well construction method | Materials for which best suited | Water table depth for which best suited ft | Usual maximum depth | | Usual casing material | Customary use | Yield ¹ gal/min | Remarks |
|--------------------------|---|---|---------------------|--------|---|--------------------|-------------------------------|---|
| | | | ft | in | | | | |
| Driven wells | | | | | | | | |
| Hand, air hammer | Silt, sand, gravel less than 2 inches | 5–15 | 50 | 1.25–4 | Standard-weight pipe | Domestic, drainage | 3–40 | Limited to shallow water table, no large gravel |
| Jettied wells | | | | | | | | |
| Light, portable rig | Silt, sand, gravel less than 1 inch | 5–15 | 50 | 1.5–3 | Standard-weight pipe | Domestic, drainage | 3–30 | Limited to shallow water table, no large gravel. |
| Drilled wells | | | | | | | | |
| Cable tools | Unconsolidated and consolidated medium hard and hard rock | Any depth | 1,500 ^{2/} | 3–24 | Steel, wrought iron, fiberglass, or plastic pipe ⁸ | All uses | 3–3,000 | Effective for water exploration. Requires casing in loose materials. Mud-scow and hollow rod bits developed for drilling unconsolidated fine to medium sediments. |
| Hydraulic rotary | Silt, sand, gravel less than 1 inch; soft to hard consolidated rock | Any depth | 1,500 ^{2/} | 3–18 | Steel, wrought iron, fiberglass, or plastic pipe ⁸ | All uses | 3–3,000 | Fastest method for all except hardest rock. Casing usually not required during drilling. Effective for gravel envelope wells. |
| Reverse hydraulic rotary | Silt, sand, gravel, cobble | 5–100 | 200 | 16–48 | Steel or wrought iron pipe | All uses | 500–4,000 | Effective for large-diameter holes in unconsolidated and partially consolidated deposits. Requires large volume of water for drilling. Effective for gravel envelope wells. |
| Air rotary | Silt, sand, gravel less than 2 inches, soft to hard consolidated rock | Any depth | 2,000 ^{2/} | 12–20 | Steel, wrought iron, fiberglass, or plastic pipe ⁸ | All uses | 500–3,000 | Very fast drilling. Combines rotary and percussion methods air drilling, cuttings removed by air. Would be economical for deep water wells. |

Figure 12-19: Water Well Construction Methods and Applications - continued

| Well construction method | Materials for which best suited | Water table depth for which best suited ft | Usual maximum depth ft | Usual diameter range in | Usual casing material | Customary use | Yield ¹ gal/min | Remarks |
|--------------------------|---|---|---------------------------|----------------------------|--|--------------------------------|-------------------------------|--|
| | | | | | | | | |
| Sonic (vibratory) | Soft to hard consolidated rock | Any depth | 2,000 ² | 12-20 | None in consolidated rock | All uses | 500-4,000 | Rapid hole advance in rock and unconsolidated materials. |
| Augering | | | | | | | | |
| Hand auger | Clay, silt, sand, gravel less than 1 inch | 5-30 | 35 | 2-8 | Sheet metal or plastic | Domestic, drainage | 3-50 | Most effective for penetrating and removing clay. Limited by gravel over 1 inch. Casing required if material is loose. |
| Power auger | Clay, silt, sand, gravel less than 2 inches | 5-50 | 75 | 6-36 | Concrete, steel, wrought iron, fiberglass, or plastic pipe | Domestic, irrigation, drainage | 3-100 | Limited by gravel over 2 inches, otherwise same as for hand auger. |

1 Yield influenced primarily by geology and availability of groundwater.
 2 Greater depths reached with heavier equipment.
 3 Care must be used in selecting material and designing casings for greater depths. See NEH(3)1.32.

D. Hydraulics

- (1) Groundwater movement into a well is radial and three-dimensional. Figure 12–20 shows two-dimensional groundwater flow into a typical water table aquifer pumping well. The figure also provides groundwater terminology. See Section 650.1206, Definitions, for definitions of terms.
- (2) The flow from an aquifer into a well requires a change in water level and in energy measured from that of the static water level. The slope of this change is steepest near the well and determines the cone of depression (figures 12–20 and 12–21). The dimensions that the cone develops depend on the pumping rate, the time since pumping started, the transmissibility, and the storage coefficient. The cone of depression will continue to expand until the recharge of the aquifer equals the pumping rate. Recharge occurs and stabilizes when the cone enlarges to intercept enough of the aquifer's natural recharge or a body of surface water, or until there is enough precipitation on the area above the cone of depression or leakage through overlying or underlying formations.

Figure 12-20: Diagram Showing Groundwater Terminology

Figure 12-21: Typical Irrigation Well in Unconsolidated Materials



- (3) When the recharge rate does not equal the pumping rate, the cone of depression grows in depth and width, and yields for the pumping depths may become uneconomical. Another factor is that the cone of depression may expand and intercept the cone of another pumping well, resulting in well interference and loss of efficiency. Whether a favorable recharge is occurring can be determined by conducting an aquifer test.

E. Aquifer tests

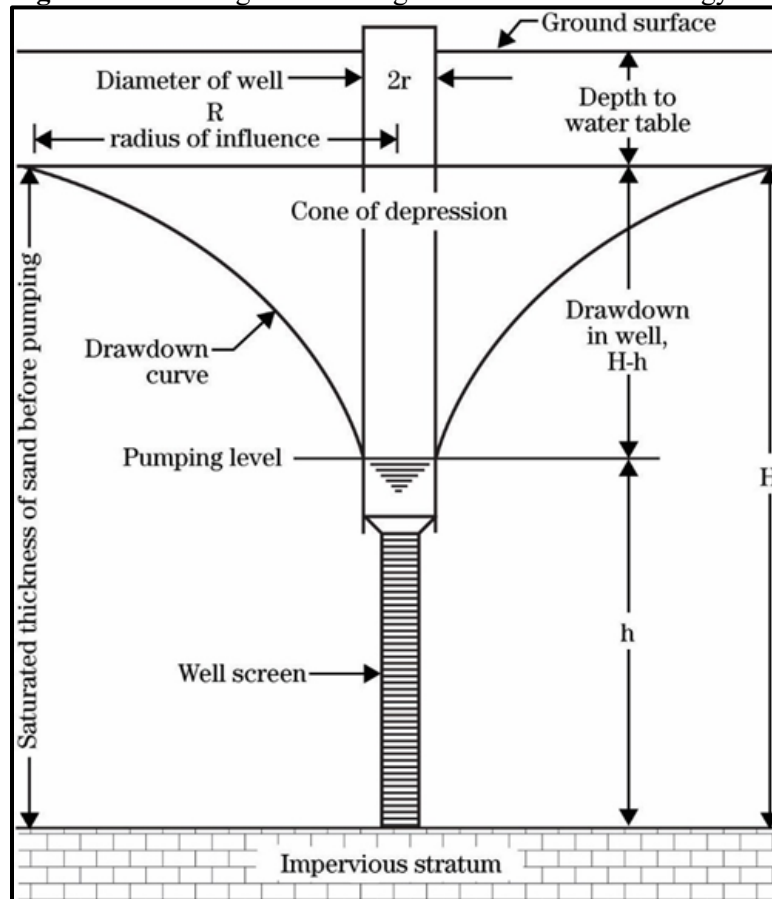
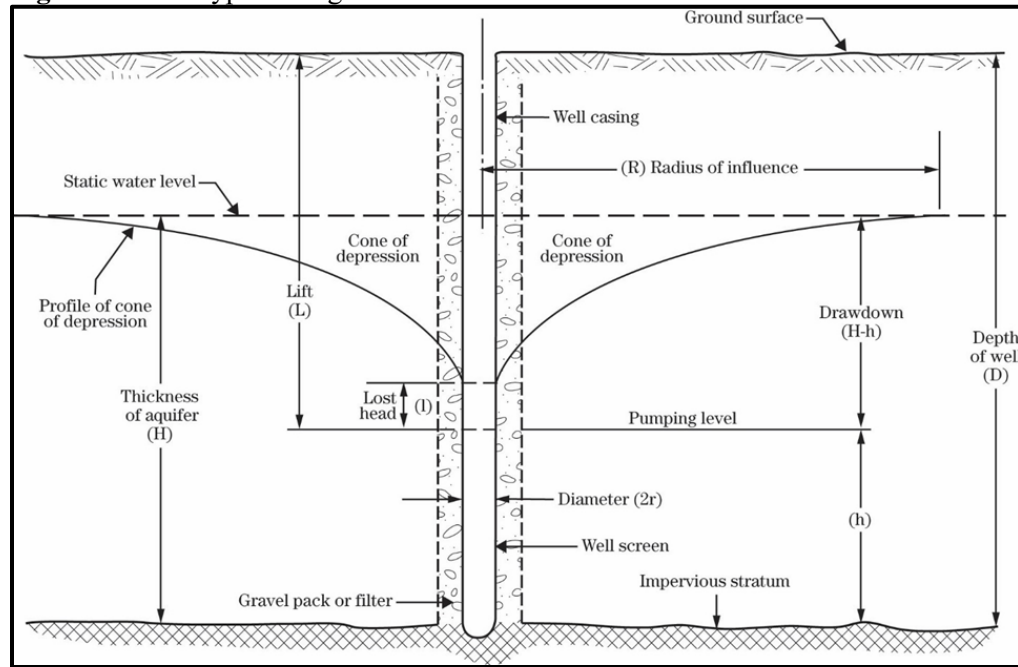
- (1) You use aquifer tests are for:
 - (i) Determining dependability of storage volume and recharge characteristics
 - (ii) Defining the yield-drawdown relationship, or the well's specific capacity
 - (iii) Analyzing formation samples
 - (iv) Analyzing the water quality for corrosion and encrustation potential, and overall chemical quality for the intended use
 - (v) Identifying aquifer characteristics
- (2) Collect the following information during an aquifer test:
 - (i) Measured static water level depth, date and time recorded, and method of measurement
 - (ii) Construction of a test well and sometimes observation wells:
 - Depth of water well
 - Length of casing and screening
 - Length of casing (stick-up) above ground surface
 - ID of well bore or casing
 - Type of casing material or ASTM material schedule and joint type (e.g., standard weight steel, PVC Schedule-80)
 - Screen slot size
 - Type and length of filter material
 - Sealing material and grout (e.g., bentonite, cement, or admixtures) and quantities used

- (3) Types of data collection
 - (i) Aquifer test to show the time, drawdown (distance from the static water table before pumping to the water level in the casing during pumping), and distance-drawdown information
 - (ii) Aquifer test to determine step-drawdown depths
 - (iii) Determining the time required for water level recovery after pumping

F. Design Planning

- (1) Obtain information needed in designing a well from a study of logs and sieve analyses of samples from test holes. The samples must be representative of the aquifer materials. Observe items listed in section 650.1203B “Site Selection”. If site information is not available, records of nearby wells will be helpful. If area information is not available, a geologic report on the site will provide the best basis for design decisions.
- (2) Use geologic, engineering, and economic considerations, and standards’ requirements to make the following design decisions.
 - (i) Drilling method
 - (ii) Earth materials
 - (iii) Diameter and depth of hole
 - (iv) Position, size, and number of casing perforations
 - (v) Need for a well screen
 - (vi) Need for a gravel envelope
 - (vii) Choice of well development method
- (3) A properly designed and constructed well is a conservation practice. See CPS Code 642, Water Well, for current criteria. Note that State and local requirements and criteria may differ.
- (4) Design a well to fit site conditions and document the information during construction. At minimum, record the information shown in figures 12–22 and 12–23.
- (5) Make final design decisions as well drilling proceeds. Refer to 210-NEH-631-32 “Well Design and Spring Development” for methods of analyzing essential information to design an efficient well.
- (6) For design purposes, analyze the well as two parts: the cased section and the intake section. Before the actual design is started, prepare a design outline that includes the amount of water required, annual pumpage and duration, economic life of the well, type of production system, type of well, materials to be used in the well, and cost estimates for installation, pump, well materials (screen, casing, etc.), testing, and well development.

Figure 12-22: Documentation of Water Table Well Design

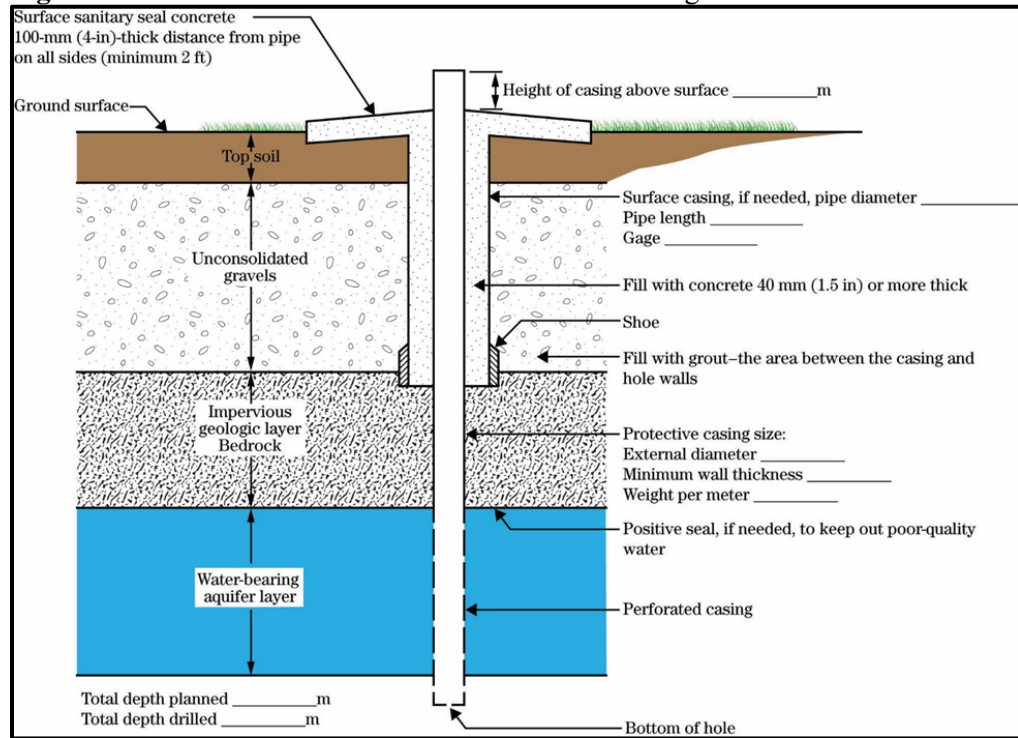
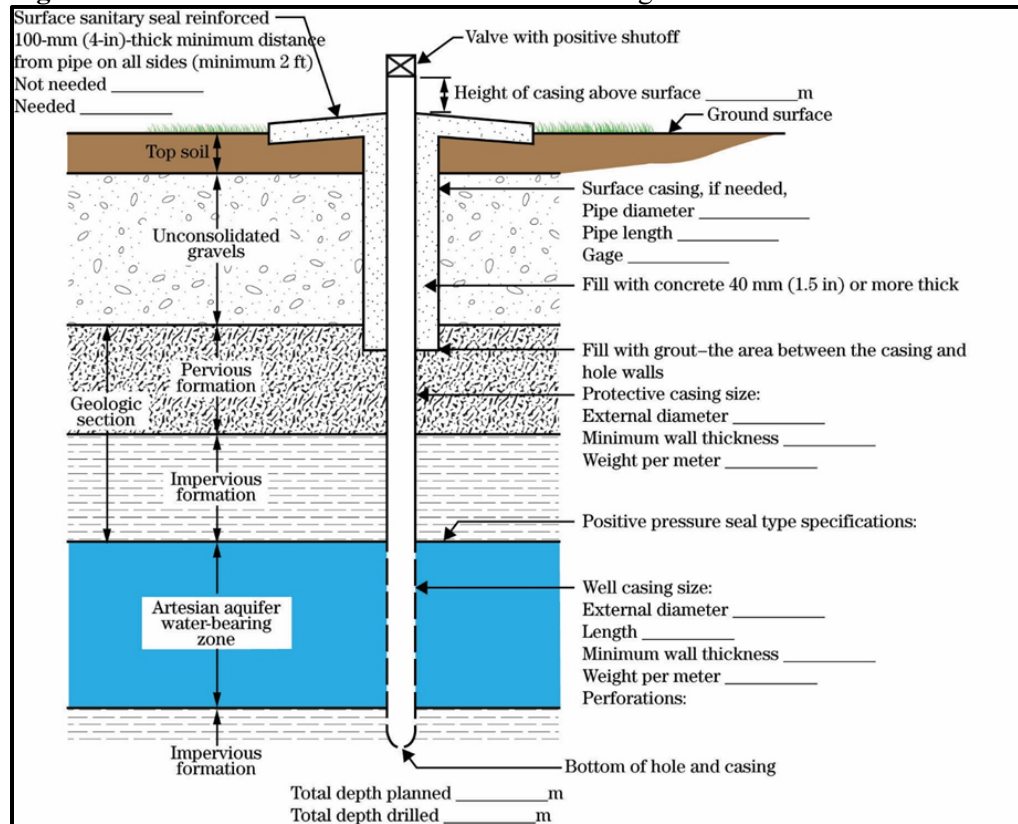

Figure 12-23: Documentation of Artesian Well Design



G. Design Capacity

- (1) Potential well capacity — Before selecting a casing diameter, pump size, screen or slot size, the potential well capacity or yield must be known.
- (i) Well in Unconsolidated Material — These factors affect the capacity of a well in unconsolidated sand or gravel formations.
- Physical characteristics—Physical characteristics that influence well capacity are size, porosity, and uniformity of the water-bearing materials. Generally, sands suitable for irrigation development have a porosity of 20 to 40 percent of the volume of the water-bearing material. A uniform sand has greater porosity and more water-bearing capacity than a nonuniform sand.
 - Depth of water-bearing formation—The depth from the static water level to the bottom of the well or the impervious stratum determines the amount of drawdown that a well can have. Drawdown influences the slope and velocity of the water approaching the well and helps determine the well capacity. Other factors being equal, well capacity is in proportion to $H - h$, where H is the depth of water-bearing formation and h is the depth of water remaining in the well while pumping, measured on the outside of the casing. See figures 12–20 or 12–21.
 - Use the following formula to predict the capacity for any desired drawdown or the drawdown for any desired capacity of a well, if the discharge and drawdown are known for a given condition:

$$\frac{Q}{Q_1} = \frac{H^2 - h^2}{H^2 - h_1^2}$$

where: Q = measured well capacity at known drawdown depth
 Q_1 = well capacity at desired drawdown depth
 H = saturated thickness (static head) of water table aquifer
 h = depth to static drawdown level in well during pumping
 h_1 = desired static drawdown level in well during pumping

- Refer to section 650.1208(A) “Example Problem to Estimate Capacity”
- Extent of water-bearing formation—Formation influences limit the total quantity pumped from a well. A blocked off water supply on one or more sides, naturally restricts flow.
- Diameter of well—The diameter of the well is more important in allowing proper pump installation than in determining the well yield. Doubling the diameter of a well increases the capacity by only about 13 percent.
- Effectiveness of screen or casing—Consider the open area of casing perforations or well screen needs in determining well capacity.

- Computing probable capacity—Use already derived discharge formulas for equilibrium conditions for water table aquifers and artesian aquifers. Assume that recharge is at the periphery of the cone of depression (figure 12-21). The formula for capacity of a water table aquifer is:

$$Q = \frac{K(H^2 - h^2)}{1,055 \log R/r}$$

where: Q = well capacity or pumping rate, gal/min

K = permeability of aquifer, gal/d/ft²

H = saturated thickness of the aquifer before pumping, ft

h = depth of water in the well while pumping, ft

R = radius of the cone of depression, ft

r = radius of the well, ft

- A properly constructed well in a water table aquifer should yield about 90 percent of its capacity when the drawdown is about two-thirds of the depth of the static water level. The radius of influence for an average well of 12 to 18 inches in diameter is between 200 and 1,000 feet.
 - The quantity of available water moving into a well increases rapidly as the aquifer grain size increases. The effective diameter of sand, the D_{10} size, can be determined by screening samples of the aquifer formation. Estimate the porosity percentage by compacting a sample of the aquifer formation material to its natural state in a quart jar and then measuring the quantity of water needed to fill the voids.
- (ii) Artesian Well — The formula for capacity of an artesian aquifer (figure 12-24) is:

$$Q = \frac{Pm(H_2 - h_1)}{528 \log R/r}$$

where: Q = gal/min

P = permeability of the water-bearing sand, gal/d/ft²

m = saturated thickness of artesian aquifer, ft

H = static head (or depth) of water in well measured from bottom of aquifer, ft

h = depth of water in the well while pumping, ft

R = radius of the cone of depression, ft

r = radius of the well, ft

- (iii) Permeability of an artesian or water table aquifer must be determined from laboratory or field tests.
- (iv) The cavernous-formation aquifer supports an ideal well if the underground supply is adequate and recharge is rapid. Pump the water from the bottom of the well casing; no well screen required. Supply and recharge of the underground reservoir are the limiting factors on yield.
- (v) A sandstone-formation aquifer is usually a low producer per unit of depth; it may produce only about 1 gallon per foot per minute. However, if cracks or crevices are frequent, wells in this formation may produce up to 5 gallons per foot per minute.

Figure 12-24: Diagram Showing Terms used in the Artesian Aquifer Equation

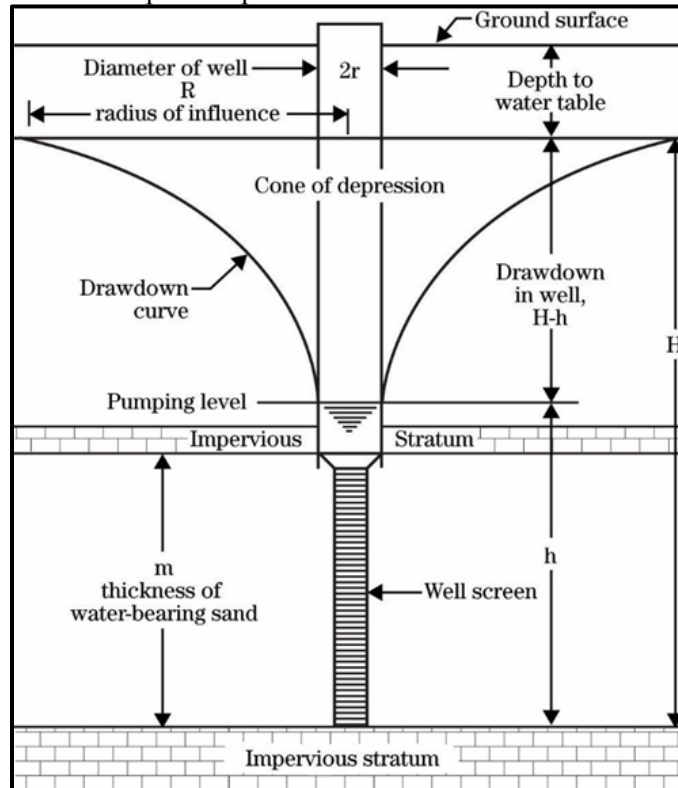

- (2) Specific Capacity — The well's pumping rate (gpm) divided by the drawdown depth in the well (ft) or gallons per minute per foot is the specific capacity of a well. The specific capacity integrates all the variables that affect water yield, including the aquifer characteristics and the well design, construction, and condition. A recorded change in specific capacity over time indicates either changes occurring in the aquifer or (more likely) changes in the condition of the pump, screen, or casing.

H. Diameter

- (1) Consider the following items in determining the diameter of a well:
 - (i) Diameter necessary for installing a pump able to lift the maximum amount of water to the projected elevation with the best pumping efficiency
 - (ii) Yield capacity of the aquifer
 - (iii) Aquifer characteristics
- (2) The relationship between well diameter and yield is not proportional and depends on numerous factors. For unconfined aquifers, the table in figure 12-25 shows the approximate increase in yield by changing the diameter of the casing. For artesian aquifers, the increased yield is about half that shown in the table.
- (3) Factors such as depth, pump characteristics, layout, and method of developing the well are more important than capacity in determining well diameter. Generally, developing two medium-sized wells, such as a 10-inch or 12-inch well, costs less than developing one large well, such as a 24-inch or 36-inch well. The combined yield of the smaller wells is almost always much greater than the yield of the larger well.

Figure 12-25: Changes in Yield with Increase in Well Diameter

| Well diameter inches | | | | | | | | |
|--|----|----|----|----|----|----|----|----|
| 2 | 4 | 6 | 8 | 12 | 18 | 24 | 36 | 48 |
| Percent increase in yield (read across only) → | | | | | | | | |
| 0 | 10 | 15 | 20 | 25 | 33 | 38 | 48 | 55 |
| | 0 | 5 | 10 | 15 | 23 | 28 | 38 | 45 |
| | | 0 | 5 | 10 | 18 | 23 | 33 | 40 |
| | | | 0 | 5 | 13 | 18 | 28 | 35 |
| | | | | 0 | 8 | 13 | 23 | 30 |
| | | | | | 0 | 5 | 15 | 22 |
| | | | | | | 0 | 10 | 17 |
| | | | | | | | 0 | 7 |
| | | | | | | | | 0 |

I. Efficiency

Well efficiency is the ratio of theoretical drawdown to actual drawdown and is a function of the design. It is not uncommon for a well to be only 60 percent efficient. However, with good construction and development, up to 90 percent efficiency is possible.

J. Cased Section

The cased section is the upper part of the well. It includes the borehole, the casing, well stabilizer, sanitary protection, and surface protection. Following are casing considerations.

- (1) Borehole — The borehole must be large enough to permit the insertion of casing, gravel pack, and the well stabilizer material. It must be large enough to accommodate the required flow and the necessary parts of the selected pump. A vertical well should be deep enough to extend to the bottom of the water-bearing strata and should be straight and plumb, which may require the use of centering guides. A well less than 12 inches in diameter generally cannot accommodate a pump large enough to supply enough irrigation water. Shallow wells with centrifugal-type pumps can be as a battery of wells connected with a manifold. In this case, drill 6- to 8-inch diameter wells or drive 2- to 4-inch diameter wells.
- (2) Casing — The casing is the inner lining of the well that holds the hole open. It also provides a conduit for installing the pump, pump column, or drop pipe. Use casing wherever unstable material might cave in or where water from contaminated strata has the potential to contaminate the well. In a dug well, the casing is usually brick, stone, or concrete. In all other types of wells, the casing material may be plastic (PVC or ABS), styrene-rubber, steel, fiberglass, reinforced plastic mortar, or concrete. The type of casing selected depends on the corrosion and encrustation potential of the water and the strength required for the well site. Take precautions to ensure that joints are watertight when in installing the casing.

- (3) Well Stabilizer — The well stabilizer is material used to fill and seal the annular space between the well hole and the casing above the intake section. The well stabilizer must have no gaps or bridges. If separation occurs in placing the column of materials, the void could cause the casing to collapse.
- (4) Sanitary Protection — All wells should have sanitary protection. State laws may vary. However, the well casing should terminate not less than 1 foot above the ground surface and have a watertight cover or seal to prevent contaminated water or other objectionable material from entering the well. Fill the annular space around the casing with cement grout, bentonite clay, or other suitable materials. Artesian wells require a positive seal between the casing and the impervious material overlying the aquifer.
- (5) Surface Protection — A concrete slab with watertight connections outside the casing and extending at least 2 feet beyond the well hole is usually adequate. Extend it to serve as a base for pumping equipment, if needed. Internal combustion engines should have a separate base to prevent damage by vibration. Provide additional cover if pumping equipment does not cover and seal the top of the casing. Make provisions to allow water-level monitoring.

K. Intake Section

- (1) The most important part of the well is the intake section. This consists of the screen or slot section and the gravel pack or filter. The design and installation of the intake section affect the well's efficiency.
- (2) Well screens—Installed at the lower end of the casing to permit water to flow into the well from the desired or targeted aquifer interval, while retaining the coarser aquifer materials around the well. The screen also permits removal of finer materials during the well development process. Screens must have an open area of at least 15 to 20 percent of their surface to keep entrance head losses to a minimum.
 - (i) Manufactured screens according to several designs and from a variety of corrosion-resistant materials. Screens made of nonmetallic materials are also available.
 - (ii) The screen or perforated length is the first selection in the design of the intake section. The formation thickness, the aquifer type, stratification, and design efficiency dictates the length of the screen in the design.
 - (iii) Present aquifer types govern screen length. The four types are homogeneous and nonhomogeneous artesian aquifers, and homogeneous and nonhomogeneous water-table aquifers. Screen design principles include the following:
 - Screen 70 to 80 percent of the thickness of the water-bearing sand in homogeneous artesian aquifers.
 - The screen length for nonhomogeneous artesian aquifers must be determined from sieve analyses of the formation.
 - Theory and experience have shown that screening the bottom third of homogeneous water-table aquifers is adequate.
 - -Design screens for nonhomogeneous water-table aquifers the same way as those for nonhomogeneous artesian aquifers.
 - (iv) Case a third to half of the water-bearing stratum with a screen or perforated casing. Some formations require no casing. Most of the water is from the lower third of the water-bearing stratum.

- (v) When the pump is operating, the cone of depression lowers the water around the casing so that no water enters along the upper portion of the water-bearing formation. A perforated casing or screen in this area is an added expense with no benefit derived from its use and is often a source of trouble.
- (vi) When a section is alternately above and below water, corrosion weakens it and may cause it to cave-in. Water entering the casing above the water level inside the casing can entrain air and cause problems in pipeline operation where the pump connects directly to the pipeline. Compute the length of the perforated section needed to keep the head loss through the screen less than 2 feet using the following formula:

$$L = 6 \frac{D}{C}$$

where: L = length of screen or perforated section

D = diameter of screen or casing

C = Screen coefficient = $11.31 C_c A_p$

where: C_c = orifice coefficient of contraction for the screen opening
(assume ~ 0.62)

A_p = ratio of total area of screen openings to total area of screen

- (vii) The size of slots in screen or casing should be $<D_{85}$ and $>D_{60}$ size of the filter. For naturally developed wells, the slots should be small enough to exclude about a third of the aquifer formation. Usually, a screen or casing with 15 to 20 percent open area will cause a small enough head loss for efficient operation of the well. Size gradations of aquifer material or filter material are determined through sieving of samples with standard wire-mesh sieves.
- (viii) The characteristics of the water-bearing formation dictate the screen length and slot size so the well screen diameter can be varied to meet hydraulic conditions. The main factor that governs screen diameter is limiting the water entrance velocity to reduce clogging, corrosion, or encrustation. Calculate the entrance velocity by dividing the expected or desired yield of the well by the total area of the openings in the screen.

$$V_e = \frac{Q}{A_s}$$

where: V_e = screen entrance velocity, ft/s

Q = well yield, ft³/s

A_s = open area of screen (ft²)

- (ix) A conservative water well design has a well screen entrance velocity of about 0.1 foot per second, which has been the common industry standard for many years. The American Water Works Association Standard A-100-06, however, no longer stipulates a maximum screen entrance velocity and cites recent research and testing that indicate that allowable well screen velocities are a function of the aquifer characteristics, the overall well design and intended performance, and the quality of the groundwater being pumped. The maximum recommended entrance velocity should be less than 0.7 foot per second.

- (x) Generally, either a manufactured well screen or a factory-perforated casing should have a sharp outer edge, and the perforations should be larger on the inside than the outside to permit the passage of sand grains entering the perforations. Do not use torch-cut perforations because the ununiform cuts are larger on the outside than on the inside. They tend to become clogged with sand or gravel grains. Manufacturers of well screens or perforated casing will supply information on the area of perforations for any given diameter, opening size, and capacity per foot of length per foot of head loss.
- (3) Filter pack—Use a sand or gravel filter pack in wells developed in strata composed of fine material of relatively uniform size so that aquifer materials cannot pass through the well screen or perforated casing.
- (i) The filter must exclude sand and finer materials from the well and permit maximum flow of water from the water-bearing formation to the well screen or perforated section. Install a gravel filter pack with the well screen equipped with centering guides. These guides will assure the uniform placement of the gravel pack.
 - (ii) The design criteria for the filter are based on a sieve analysis of the dried aquifer material.
 - (iii) Use the coefficient of uniformity (C_u) of the aquifer to determine the need for a gravel pack. Determine the C_u is by dividing the D_{60} size by the D_{10} size (Hazen formula):

$$C_u = \frac{D_{60}}{D_{10}}$$

- (iv) Sands with a $C_u < 2$ do not benefit greatly from development by surging (section 650.1205M. “Well development after installation”). Sands with $C_u > 2$ but < 3 may benefit from development by surging, but water will flow through the aquifer freely enough that surging is not essential.
- (v) Meet the following five conditions in selecting the size of gravel or filter material:
 - C_u of the filter material should be < 2 .
 - D_{15} size of the filter material should be $> 4 \times D_{15}$ size of the aquifer material.
 - Include the uniformity of the aquifer in the criterion for a filter. If D_{50} filter/ D_{50} aquifer < 7.5 , the movement of sand into the filter should not be excessive. This conclusion is based on experiments with aquifer C_u 's of less than 2, so the D_{50} size of the filter can be at a maximum of $7.5 \times D_{50}$ size of the aquifer. Assume this same criterion will hold true when aquifers with C_u 's higher than 2 are gravel packed, determine the maximum D_{50} size of the filter by the following formula.

$$C_u = \frac{D_{60}}{D_{10}}$$

$$D_{50} (filter) = \frac{15 \times D_{50} (aquifer)}{C_u (aquifer)}$$

- The D_{85} size of the filter should be $< 2.5 \times D_{10}$, to keep the C_u within 2.
- The filter gradation curve should be as nearly parallel to the aquifer gradation curve as the above conditions will allow.

- (vi) The table in figure 12-26 provides general guidance for filter packs, based on aquifer characteristics.

Figure 12-26: Guidance on When to Use a Gravel Pack Table

| Coefficient of Uniformity (C_u) | Aquifer Grain Size (D_{60}) | Gravel Pack Recommendation |
|-------------------------------------|---------------------------------|--|
| $C_u < 2$ | — | Use gravel pack |
| | $D_{60} < 0.76$ mm | Use gravel pack |
| | 0.76 mm $< D_{60} < 2.54$ mm | Omit gravel pack if well screen has enough openings to allow water to enter well without excessive head loss |
| $2 < C_u < 3$ | $D_{60} > 2.54$ mm | Do not use gravel pack; use a manufactured well screen or perforated casing |
| | — | Omit gravel pack because it might hold back fine sand removed from the aquifer by natural development |

- (vii) The procedure to use in applying the above conditions to determine the size of filter material is:

- Step 1. Make a sieve analysis of aquifer material to determine the percentage smaller than the screen openings.
- Step 2. Compute and locate on graph the D_{50} size of the filter as determined in 650.1205K(2)(v) third bullet.
- Step 3. Assume that D_{10} , D_{50} , and D_{60} are in a straight line. The C_u should not exceed 2; then D_{10} minimum size would be D_{50} size $\times 0.6$. Locate this D_{10} minimum point on graph.
- Step 4. Locate the maximum D_{85} size of the filter at $2.5 \times D_{10}$ size.
- Step 5. Plot a uniform filter curve through the D_{50} point as nearly parallel to the aquifer curve as the above minimum D_{10} and maximum D_{85} points will permit.
- Step 6. Check to see that the D_{15} minimum size meets the requirement of being $> 4 \times D_{15}$ size of aquifer. If not, move the D_{15} point to meet this requirement and replot the filter curve through this point and the D_{50} point with a C_u less than 2 to fit a new curve.

- (viii) See 650.1208B for a filter design example problem.

L. Multiple Well Systems

- (1) If needed, use a multiple-well or manifold system to obtain the amount of water to meet design requirements. Three conditions are necessary for a manifold system to be successful.
 - (i) The water table should be close enough to the land surface to permit pumping the wells by suction lift.
 - (ii) The water-bearing sand and gravel should permit good water yield without excessive drawdown, and the stratum should be thick enough to permit prolonged pumping.

- (iii) The individual wells must be highly efficient. Investigation, casing, and screen selection are the same for a multiple-well system as for any other well.
- (2) There are two types of installations that use multiple-well systems: sand points and small individual wells. Figure 12–27 shows the components for a satellite well unit. Figure 12–28 shows a typical manifold multiple-well system with four satellite wells. Add additional satellite wells to a system if needed.
- (3) Figure 12–29 shows several layouts of satellite wells relative to the central well. The general configuration of the aquifer with respect to the overlying property largely dictates which arrangement is best. Drilling test wells may be necessary to locate the aquifer and define its characteristics.
- (4) No exact spacing of the wells can be set. Sometimes the water supply will be adequate on 10-foot spacings. However, it is good practice to space wells at least 40 feet apart so interference between them will be at a minimum. After the first well is set, the remaining wells can be set by connecting the pump discharge to them and jetting them into place.
- (5) A drop pipe installed in each of the well is connected to the manifold or header pipe, which in turn is connected to the intake side of the pump.
- (6) All connections on the suction side of the pump must be airtight. The practical suction lift on most suction pump is 25 feet or less. A common practice with satellite wells is to drill and case to about 35 feet below the normal water table in the aquifer.
- (7) The drop pipe extends to within 2 feet of the bottom of the well, making it about 30 feet below the manifold line. The manifold line may be on the surface of the ground or buried close to normal water level.
- (8) The size of manifold lines depends on the friction loss, the volume of water flowing, and the distance that water flows through the pipe. If more than one well is on a manifold, increase the pipe size as the pipe approaches the central well. Each manifold is an individual design problem.
- (9) Install manifold lines with a slight incline toward the central well. This prevents incline prevents high points that trap air pockets and reduce the flow.
- (10) Drill an observation well at some measured distance from the well and determine the drawdown at that point. If the drawdown at the well (outside the casing) is known, the radius of influence can be determined. For example, when measured, 40 percent of drawdown is at 50 feet from the well, then 20 percent drawdown will be at 100 feet from the well, 10 percent drawdown at 200 feet from the well, and 5 percent drawdown at 400 feet from the well. If possible, space wells at least twice the radius of influence as determined above.
- (11) Closer spacing causes interference between the wells (figure 12-30). Wells spaced 800 feet in the above example would have radii of influence overlapping each other at the 5-percent drawdown point, causing interference and inefficiency.

Figure 12-27: A Satellite Well Unit of a Multi-well System

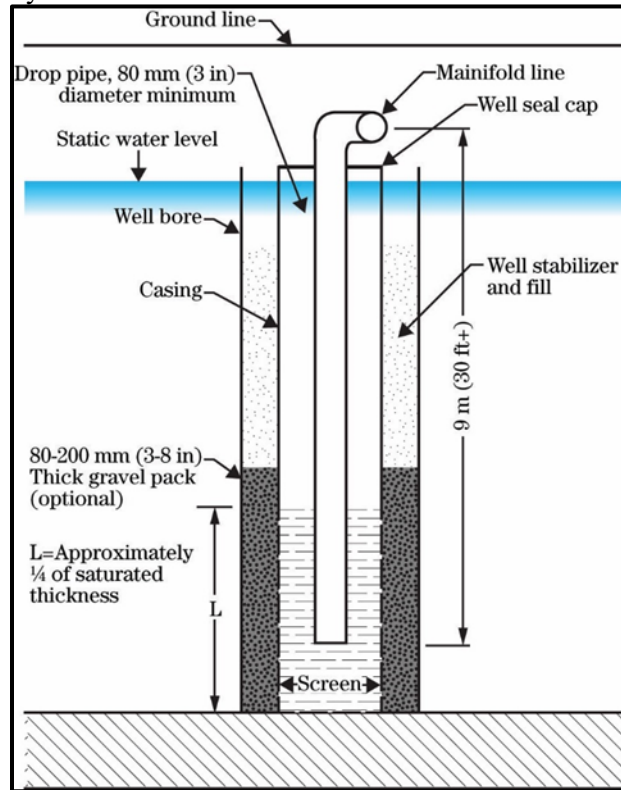

Figure 12-28: Typical Multi-well Manifold System (Pump may be an engine or electric motor)

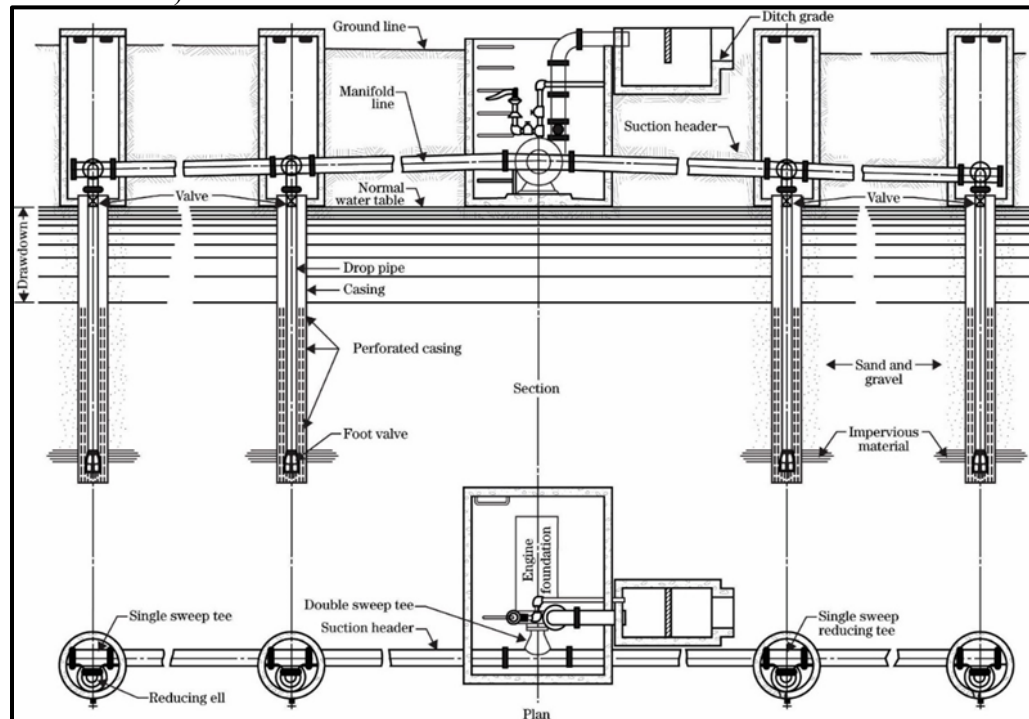

Figure 12-29: Sample Layouts for Manifold Pumping Systems

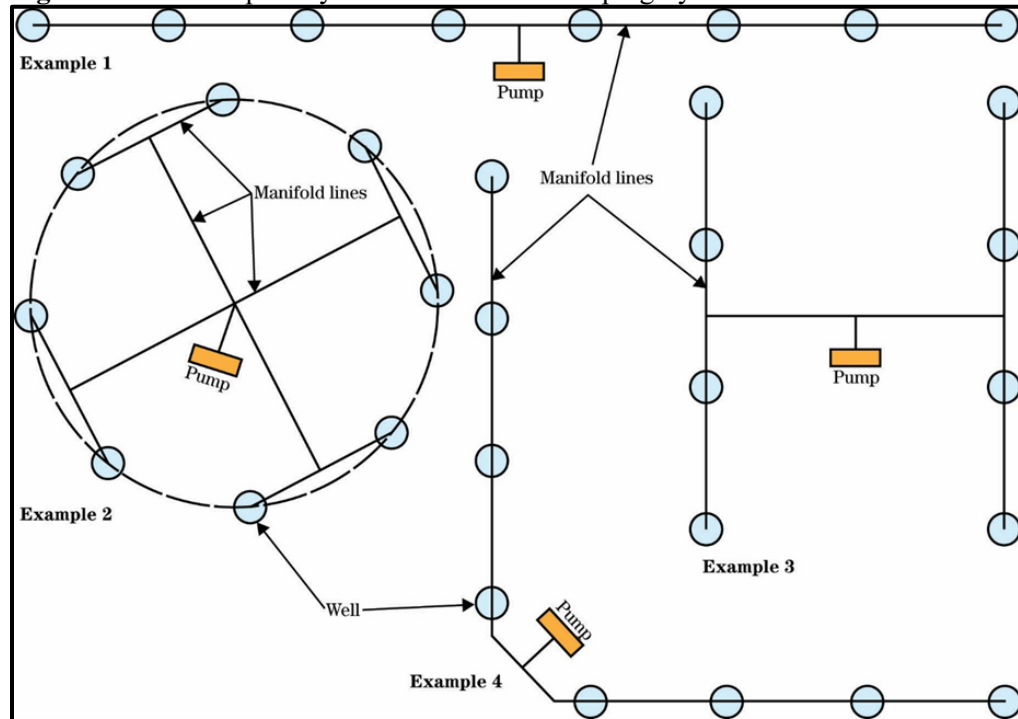
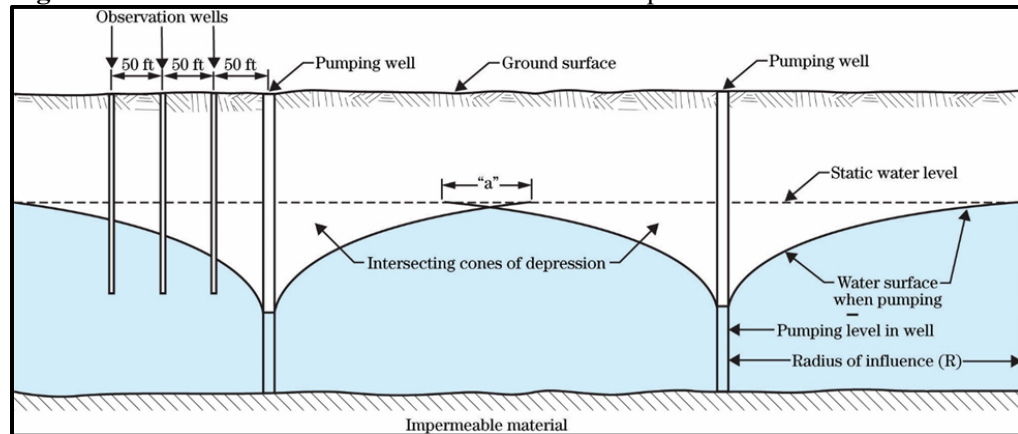

Figure 12-30: Well Interference in an Unconfined Aquifer



M. Construction

- (1) Have all required construction equipment and materials to finish the well at the site before drilling starts.
 - (i) Avoid leaving a hole open for any length of time; swelling, caving in, and sloughing of formation materials might permanently damage the well and lessen its yield. Construct a hole of constant diameter and alignment.
 - (ii) Use extreme care to place the screen and casing according to the manufacturer's recommendations.
 - (iii) In placing the formation gravel stabilizer and gravel or filter pack, avoid the separation or bridging of material.

- (2) Wells should be spaced far enough apart that their radii of influence do not intersect as at “a.” Depending on the permeability of the aquifer and the drawdown, the radius of influence, R , may range from 100 to 3,000 feet or more, determined with observation wells spaced at regular intervals away from a pumping well.
- (3) Check the well after it is ready for testing, and check various parts of the well before and during construction:
 - (i) Diameter of the hole
 - (ii) Quality and placement of the gravel pack
 - (iii) Quality, size, and placement of the screen
 - (iv) Quality and dimensions of the casing

N. Well Development after Installation

- (1) The purpose of development is to condition the well to produce the maximum amount of sediment-free water with minimum drawdown. Development is the last operation in constructing a well. It is the mechanical removal of fine sand, silt, and clay from the aquifer around the well, forming a natural gravel envelope. Or, if no coarse particles are present, it removes fines through an artificial gravel envelope. Development is essential to completing wells satisfactorily in unconsolidated materials. Figure 12–31 shows a cross section of a filter pack in a developed aquifer, along with the well screen.

Figure 12-31: Cross Section of Developed Well Showing Filter Pack and Well Screen

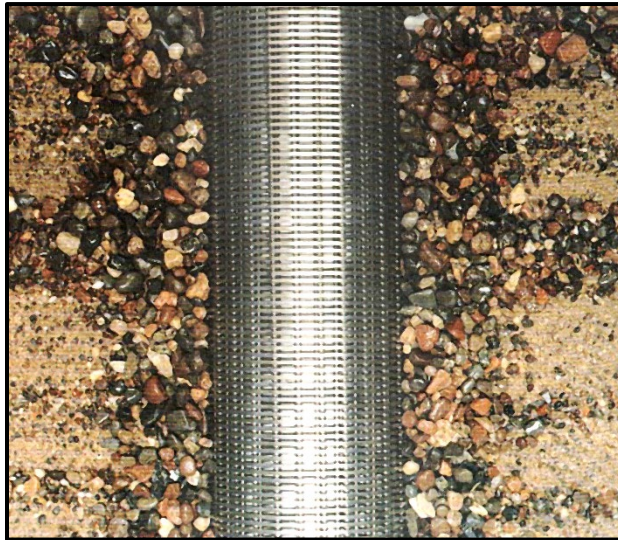

- (2) Develop wells by surging, backwashing, jetting, pumping, use of compressed air, dry ice, acid, or dispersing agents. Use packers (inflatable or mechanical) to separate or isolate water-bearing strata during well development. Use knowledge of drilling methods and formation reactions to development to select the proper method. Use information from the record of materials to guide the development process.
- (3) Bridging of fine sand in the aquifer near the well may result from too violent action at the beginning of work. When pumping the well, sand particles in the formation tend to move toward the well. Because the steady pull of pumping is in one direction, finer sand grains wedge against each other and bridge across openings between coarser grains. To prevent bridging and remove fine grains, keep the water agitated by reversing the direction of flow.

O. Testing

- (1) Pump a well to determine its capacity and drawdown. A completed well does not yield undesirable sediment when pumped at the required capacity. The contractor should complete developing and testing of the well before leaving the job.
- (2) A well usually produces about 75 percent of its capacity when the drawdown is at half the water depth and about 90 percent when the drawdown is at two-thirds the water depth. For economical pumping, design the pump to operate between these two extremes, since increasing the pumping rate to the maximum causes every gallon that is pumped to be lifted the total depth from the surface to the drawdown level. Overpumping a well may also cause excessive sand pumping and possible well failure. Soon after completion of the well and well development, install a test pump to verify the well development and yield.
- (3) Estimate the optimum yield and required lift by converting drawdown obtained from the tests to percentage of possible drawdown and relating it to yield (figure 12-32). The curves shown are average drawdown-yield relations for many wells. At 50-percent drawdown, non-artesian wells produce about 77 percent of possible yield and artesian wells produce about 55 percent.
- (4) See section 650.1208C an example on how to estimate optimum drawdown and yield and the most economical water yield from a specific well.

Figure 12- 32: Relationship between Drawdown and Yield

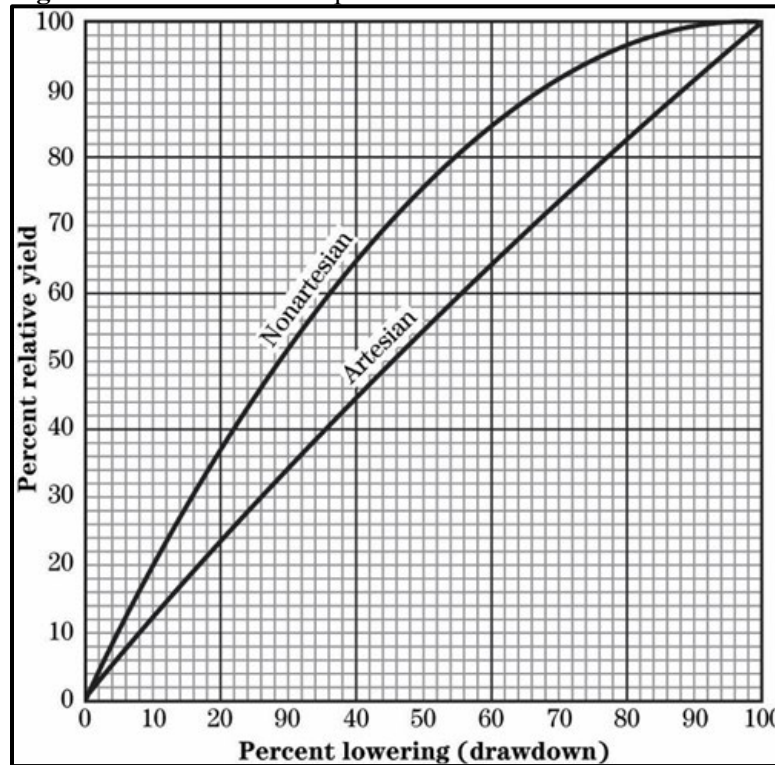

P. Measuring Drawdowns

- (1) Measure drawdown using an air pressure gage or an electric sounder. Equip deep-well pumps with pressure gages and air lines of known lengths.
- (2) Air line—The air line is usually a copper tube an eighth to a quarter inch in diameter but may be a quarter inch-galvanized pipe. Connect the surface end to a pressure gage with an air valve just below the gage (figure 12-33). The lower end of the pipe is open. The pipe must be airtight and should extend 20 feet or more below the lowest pumping level. The exact depth to the lower end of the air line must be known.
- (3) Provide air pressure by a tank connected to the line or by a hand pump. The gage indicates the pressure necessary to counterbalance the depth of water outside the air line and when it has reached maximum pressure.
- (4) Depth to water level is the depth to the lower end of the air line less the gage reading in meters or feet. If the gage reads in pounds per square inch, multiply the reading by 2.31 to obtain feet.
- (5) Electric sounder—Another satisfactory and accurate method of measuring water level is by means of an electric sounder. Electric sounders complete the electric circuit when in contact with water.

Figure 12-33: Airline Measuring Depth to Water Level

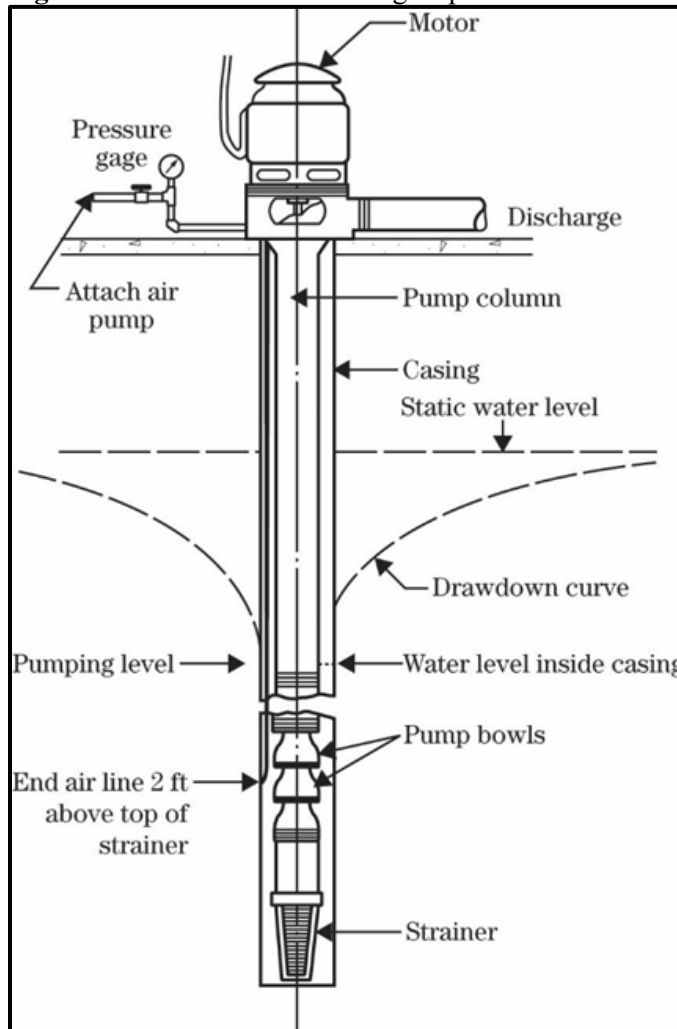

Q. Measuring Yield

An accurate well test requires careful measurement of yield. Use pipe orifices to measure discharges within a range of 50 to 2,000 gallons per minute. Use Parshall flumes or sharp-crested weirs to measure larger flows. Measure smaller yields using a container of known volume and recording time required to fill it (V/t). Use in-pipe flow meters to measure water yield, including mechanical impeller-type meters and electronic nonobtrusive meters.

R. Selecting a Pump

- (1) In selecting a pump, consider required capacity, total lift, diameter of the well, location of the well, and type of power available. The common types of pumps are turbine, centrifugal, propeller, gear, plunger, and airlift. Pump construction is based on a specific range of conditions to operate. Do not select a pump without a thorough knowledge of the planned operating conditions and pump characteristics. Figure 12–34 shows a large capacity irrigation well head, with electric motor powering the pump.
- (2) Maintenance—Proper well maintenance will extend the life of the well. Without proper maintenance, a well may fail.

Figure 12-34: Water Well Pump Powered by Electric Motor, Washington



S. Pump Service

The owners may service the pump and treat the well. Pump manufacturers issue instructions and recommendations for pump operation and maintenance. If the owner follows them, the pump should reach its expected life.

T. Water Testing

Analyze water samples before construction of a well to determine if corrosion or encrustation will be problems. Knowing this in advance enables installation of an appropriate screen or casing. Screens of various metals, alloys, and other materials are available for specific water quality applications.

U. Clogging of Intake Section

- (1) Deposits of carbonates of calcium or magnesium, deposits of clays or silts, and the presence of iron, bacteria, or slime-forming organisms in the water primarily cause screen encrustation.
- (2) Where encrustation is a problem, periodic cleaning by a reliable and experienced well servicer may be necessary. Clean the well to reduce the risk of a major reduction in yield. Select chemicals to treat wells based on the type of encrustation, screen, and casing composition.
- (3) Chlorine treatment is effective when combined with a biocide where the cause of screen clogging is bacteria that generate an iron or slime precipitate.

V. Well Testing

When it is still possible to rectify the problem, every year, make the following tests and measurements for comparison with previous data:

- (i) Each winter, when all wells have been at rest a long time, run a 2-hour pumping test. Record the static water level, the pumping rate, and frequent drawdown measurements as described under testing.
- (ii) Measure static water level and drawdown water level while pumping and determine the well's specific capacity (gal/min/ft) as an indicator of overall well performance. Changes in specific performance may indicate that well may require remediation.
- (iii) Every 2 months, all year, measure and record the static water level when the pump has been off at least 4 days. Record details.
- (iv) During the heavy pumping season, measure the yield and drawdown and record them along with the length of time that the pump has been running. Several measurements per summer are advisable.

W. Well Failures

- (1) Well failure is generally a result of continued sand pumping until the well caves in, the collapse of the well casing, or pumping the aquifer dry. A decrease in the well discharge is usually due to one or more of the following:
 - (i) A lowering of the water level or hydrostatic head in the aquifer
 - (ii) Pump or motor wear or failure
 - (iii) Poor installation
 - (iv) Filter or casing failure due to settlement of fine aquifer materials in the gravel pack
 - (v) Biological growth, iron bacteria, or chemical encrustation on the well screen or perforations

- (2) A producing well may fail completely, or its output may decrease to a level that it is uneconomical to continue its use. If the specific capacity declines by 30 percent or more, then the well may have a serious problem, requiring additional testing and troubleshooting. There is no treatment for a falling water table except to use a pumping rate or cycle that allows the water table to recharge as rapidly as water is withdrawn.

X. Applicable State Laws and Groundwater Rights

- (1) Follow state laws regarding the use of groundwater. Three principal sets of rules or “doctrines” form the basis for these laws:
 - (i) Absolute ownership, or the common-law rule, which states that the owner of the land is the absolute owner of all underground waters under their property. The owner may develop and use their groundwater without regard to effects on groundwater supplies of adjacent landowners, subject to qualifications in some States. This doctrine does not recognize flowing groundwater or the effect that its misuse may have on other landowners using the same source.
 - (ii) Ownership with reasonable use is like the common-law ownership but limits the owner to a reasonable use related to the needs of other owners of lands overlying a common groundwater source.
 - (iii) The appropriation doctrine follows the rule that, where there are reasonably established groundwater limits or boundaries, the subsurface waters are public waters and subject to appropriation. Priority rights are issued from a designated State agency after an examination of the intent of use. The appropriation system emphasizes beneficial use and conservation, security of investment, and responsibility for administrative guidance.
- (2) Most States regulate the development and administration of groundwater resources in the public interest. Common State regulations include the following:
 - (i) Licensed well drillers.
 - (ii) Submission of reports to the State on prescribed forms:
 - Drilling permits
 - Logs
 - Any work performed on wells
 - (iii) Construction and completion of wells furnishing domestic or municipal water to prevent contamination.
 - (iv) Capping or regulating the flow of flowing wells to avoid waste.
 - (v) Sealing of abandoned wells
 - (vi) Using recharge wells to return air-conditioning and cooling waters to the ground
 - (vii) Restriction of disposal of any contaminants, such as brines or industrial wastes, which affect the quality of public water supplies
- (3) Administering these regulations is usually the responsibility of a designated State agency. Administration and control of groundwater in overdraft areas pose many complex technical problems.

Y. Contracts and Specifications

- (1) Few individuals take the trouble to draw up a contract when having a well drilled. Although an oral contract is binding on both parties, it can be a source of misunderstanding because it depends on memory. On the other hand, avoid contract specifications that are too rigid lead to excessive costs.

- (2) Encourage the landowner to consult an attorney before entering a legal contract. A thorough understanding and agreement on at least the following points are necessary for a satisfactory job:
 - (i) Casing construction and specifications
 - Casing specifications
 - Casing diameter (inches)
 - Casing weight (pounds per foot) or polyvinyl chloride (PVC) class
 - Casing construction
 - Length of casing from the ground surface to the depth of termination
 - An allowance for ample overlap for the installment of two or more lines of casing for an effective seal
 - (ii) Drill the well in such vertical alignment that after perforating and testing, a deep-well pump having a clearance of 1 inch on each side can readily be installed and operated without undue stress or wear from excessive inclination of the shaft.
 - (iii) As construction progresses, the contractor shall keep, and furnish to the owner on completion of the well, an accurate record of materials passed through; water-bearing strata; progress in sinking the casing; depth, size, and number of perforations, or screen opening and dimensions; static water level; development work; drawdown; and record of testing.
 - (iv) Perforate the casing in all water-bearing strata (except quicksand) to yield a satisfactory supply of good-quality water. Use grain-size distribution of aquifer materials to size perforations according to best practice.
 - (v) Use the grain-size distribution of aquifer materials to justify the installation of a well screen, an artificial gravel envelope, or both, according to best practice.
 - (vi) After completion, surge the well thoroughly with a surge block, bailer, or other equipment until the water is sand-free. Require a payment for the work of surging or other development in dollars per hour.
 - (vii) Test the well with a pump furnished by the driller after surging and bailing the well. The pump will have a capacity in excess of expected yield and will be able to pump at variable rates. Operate the pump continuously for a specified amount time (hours). Use an air line or other suitable method to measure the drawdown periodically during pumping.
 - (viii) Require a unit price per foot of well which will include the cost of moving to and from the well site and setting up the equipment. The unit price will include perforation of the casing unless otherwise stated. Require a payment for well testing including time for installing and removing the pump in dollars per hour.
- (3) In case a dispute might arise, procedures in settling the dispute should be set forth in the contract. Large well-drilling companies have their own contract forms. For the use of a company contract, encourage the landowner to read the provisions carefully and understand the agreement before signing.

Z. Records

- (1) Maintaining complete records aids efficient and economical groundwater development. Retain copies of the records of test holes, completed well and equipment, development operations, and pumping tests in the field office and other offices as required.
- (2) Prepare a permanent file containing:
 - (i) Test hole logs and location map
 - (ii) Sieve analysis of formation samples
 - (iii) Water analysis
 - (iv) All geologic data collected in the exploration stage

- (v) Well design drawing showing accurate finished dimensions and details
- (vi) Pump specification sheets, performance curves, parts lists, etc.
- (vii) Details of repairs, acid treatments, etc.

AA. Abandonment

Seal test holes and abandoned wells in accordance with the CPS Code 351, Water Well Decommissioning, when they no longer serve their original purpose.

650.1206 Definitions

Alluvial materials—Recent materials deposited by running water. The unconsolidated sand and gravel commonly found underlying floodplains of major streams or rivers form alluvial aquifers. These sand and gravel deposits are often intermingled with silt and clay.

Annular space—The space between two cylindrical objects, one of which surrounds the other, such as the space between the walls of a drilled hole and a casing or between a permanent casing and a temporary surface casing

Aquifer—A geologic formation that will yield enough water to a well for practical use.

Artesian water—Any confined water in an aquifer that is under pressure so that it will rise in the well casing or drilled hole above the bottom of the confining layer overlying the aquifer. This term includes water of flowing wells, and water under artesian pressure in wells that do not flow.

Backwashing—Forcing the water back out of the well through the screen or slotted casing and into the water-bearing formation. Backwashing develops a well, i.e., to remove undesirable fines.

Bedrock—The consolidated or cemented rock, which may underlie the alluvium or soil, or may outcrop at the land surface.

Blotter or sand blotter—A layer of fine sand (usually about 2 feet thick) installed between the top of the gravel filter pack and the surface seal (bentonite or concrete), usually at or above the static water level. It helps maintain separation of the seal and filter so that the seal is not pulled into the gravel filter pack.

Casing—A rigid pipe installed in the well to prevent the walls from sloughing into the well.

Cement grout—A mixture of water and cement in the ratio of not more than 5 to 6 gallons of water to 94 pounds of Portland cement. For a better flowing mixture, add 3 to 5 pounds of bentonite clay to the cement and the water increased to not more than 6.5 gallons.

Cone of depression—As groundwater flows to a pumping well, the slope of the water surface increases. As distance from the well increases, the slope becomes flatter until it merges with the potentiometric surface beyond the influence of the well. The water surface within the influence of a pumped well is an inverted cone with its apex in the well and its base in the static water table.

Consolidated formation—A naturally occurring geologic formation that has been lithified (turned to stone). Bedrock is another term used for consolidated formation. It includes rocks such as basalt, rhyolite, sandstone, limestone, and shale. Commonly, this type of formation will stand at the edges of a bore hole without caving in.

- Contamination—Introduction of any chemical, organic material, live organism, or radioactive material that will lower the quality of the natural groundwater. Also included is the introduction of heated or cooled water into the groundwater if the changing of the water temperature renders the water less usable.
- Drawdown (H–h)—The distance from the position of the static water table before pumping to the level of the water in the well during pumping.
- Filter or gravel pack—A gravel envelope surrounding the well screen, designed to prevent sand from entering the well. Gravel or other permeable filter material placed in the annular space around the well screen. Use of a gravel pack is to prevent the movement of finer material into the well and to increase the ability of the well to yield water without pumping sand or sediment.
- Head loss (l)—The difference in elevation between water level inside the well (during pumping) and outside at the point where the drawdown curve intersects the casing.
- Lift (L)—The vertical distance from the water level in the well during pumping to the ground surface or some other specified point such as the center of the discharge pipe.
- Mineralized water—Any naturally occurring groundwater that has a high chemical content.
- Permeability—The ability of a geologic material (sand, for example) to transmit water.
- Porosity—The degree to which earth material contains spaces not occupied by solid particles. Porosity times the volume, usually expressed as a percentage, is the volume of water in a formation.
- Potentiometric surface—The increase in water elevation to in a tube or well that penetrates a confined aquifer. The potentiometric surface in an unconfined aquifer is the elevation of the water table.
- Pumping level (h)—Static head or depth of water in well while pumping.
- Radius of influence—The area affected by the discharge from a well, also known as the circle of influence, in plan view. The radius of the circle is the radius of influence (R).
- Sand pumping—The pumping action yields sand that is eroding from the gravel pack or the aquifer.
- Screen—A perforated, or slotted section of pipe or screen used to separate the well water from the surrounding aquifer. Its proper design allows water to flow into the well without eroding the filter pack or aquifer material.
- Sieve analysis—A procedure for measuring the percentage of various particle sizes, by weight, by shaking grain sizes in an earth material sample by shaking the sample through a series of different-sized sieves, weighing and plotting the results on a grain size distribution chart.
- Specific capacity—The well’s performance expressed as the pumping rate (yield) in gallons per minute divided by the drawdown in feet during the pumping, or gallons per minute per foot of drawdown.
- Surging—A means of developing a well by forcing water back and forth through the screen or slot area of the well casing.
- Unconsolidated materials—Naturally occurring earth deposits that have not been lithified. Alluvium, soil, gravel, clay, and overburden are some of the terms used to describe this type of deposit.

Water table—The surface level of the groundwater at the top of the saturated zone in a water-bearing formation. More properly termed the potentiometric surface.

Well stabilizer—Material placed in the annular space between the hole and the casing to hold the casing in place.

650.1206 References

- A. American Water Works Association. 2007. Standard A-100-06, Water Well. American Society of Civil Engineers, Denver, CO.
- B. Johnson, E.E. 1986. Ground water and wells. 6th ed, Johnson Division. St. Paul, MN.
- C. U.S. Department of Agriculture Natural Resources Conservation Service. 2011. National Conservation Practice Standard, Pipeline, Code 516. Washington, DC.
- D. U.S. Department of Agriculture Natural Resources Conservation Service. 2010a. National Engineering Handbook, Part 631, Chapter 30, Groundwater hydrology and geology. Washington, DC.
- E. U.S. Department of Agriculture Natural Resources Conservation Service. 2010b. National Engineering Handbook, Part 631, Chapter 32, Springs and wells. Washington, DC.
- F. U.S. Department of Agriculture Natural Resources Conservation Service. 2009a. National Engineering Handbook, Part 631, Chapter 31, Ground water investigations. Washington, DC.
- G. U.S. Department of Agriculture Natural Resources Conservation Service. 2009b. National Engineering Handbook, Part 631, Chapter 33, Ground water recharge. Washington, DC.
- H. U.S. Department of Agriculture Natural Resources Conservation Service. 2002. National Conservation Practice Standard, Water Well Decommissioning, Code 351. Washington, DC.
- I. U.S. Department of Agriculture Natural Resources Conservation Service. 2001a. National Conservation Practice Standard, Spring Development, Code 574, Washington, DC.
- J. U.S. Department of Agriculture Natural Resources Conservation Service. 2001b. National Conservation Practice Standard, Water Well, Code 642, Washington, DC.
- K. U.S. Geological Survey. 1984. Ground-water regions of the United States. Geological Survey Water Supply Paper 2242, Washington, DC.
- L. U.S. Geological Survey. 2011. The National Atlas of the United States, Washington, DC.

Appendix A – Example Problems

A. Example Problem to Estimate Capacity

- (1) Refer to Section 650.1205G. “Design Capacity”
- (2) A well has a static water level at a depth of 50 feet and a measured capacity of 850 gallons per minute with a drawdown of 34 feet. The capacity for 25 feet of drawdown would be:

$$\frac{Q}{Q_1} = \frac{H^2 - h^2}{H^2 - h_1^2}$$

$$Q_1 = \frac{Q(H^2 - h_1^2)}{H^2 - h^2}$$

$$Q_1 = \frac{850 \text{ gal/min}((50\text{ft})^2 - (50\text{ft} - 25\text{ft})^2)}{(50\text{ft})^2 - (50\text{ft} - 34\text{ft})^2}$$

$$Q_1 = \frac{850(2,500 - (25)^2)}{2,500 - (16)^2}$$

$$Q_1 = \frac{850 \times 1,874}{2,244}$$

$$Q_1 = \frac{1,593,750}{2,244} = 710 \text{ gal/min}$$

B. Filter Design Example

- (1) Refer to Section 650.1205K, “Intake Section”
- (2) Given aquifer sieve results (figure 12A-1):

Figure 12A-1: Aquifer Materials Sieve Results

| Sieve no. | % passing |
|-----------|-----------|
| 3/8 | 99 |
| 4 | 97 |
| 10 | 90 |
| 20 | 72 |
| 40 | 19 |
| 60 | 4 |

- (i) Step 1. Determine filter gradation.
- (ii) Step 2. Plot sieve results on grain-size distribution forms (Figure 12A-2).
- (iii) Step 3. Read $D_{10} = 0.3$ mm, $D_{50} = 0.65$ mm, $D_{60} = 0.75$ mm

$$C_u = \frac{D_{60}}{D_{10}} = \frac{0.75}{0.3} = 2.5$$

$$D_{50} \text{ filter} = \frac{15'D_{50}(\text{aquifer})}{C_u(\text{aquifer})} = \frac{15(0.65)}{2.5} = 3.9 \text{ mm}$$

$$D_{10} \text{ filter} = 0.6 \times D_{50} = 0.6(3.9) = 2.3 \text{ mm, minimum}$$

$$D_{85} \text{ filter} = 0.6 \times D_{10} = 2.5(2.3) = 5.8 \text{ mm, maximum}$$

- (iv) Step 4. Plot filter on curve (figure 12A-2).
 Filter design limits
- 100% pass 3/8 sieve
 - 64% (±8) or 56 to 72% pass #4
 - 6% (±8) or 0 to 14% pass #8

Figure 12A-2: Filter Design Gradation, based on Aquifer Particle size Distribution

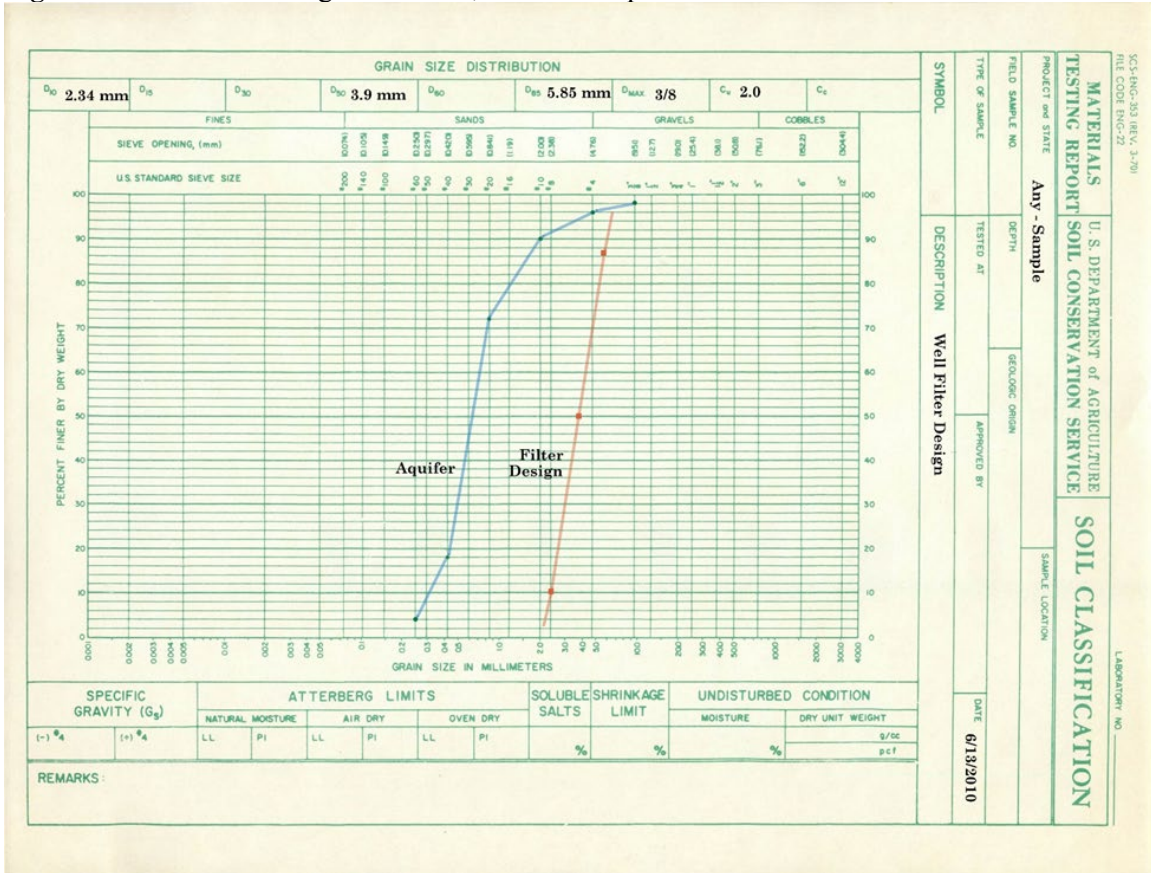

- (3) A filter from 4 to 8 inches thick is sufficient for a gravel envelope. Installing a thicker filter enlarges the effective well area and only decreases the velocity of water approaching the well. If difficulty is encountered in keeping the velocity low enough to prevent the water from carrying sand into the well, the effective diameter of the well can be increased by using a thicker filter or by installing a larger casing.

C. Optimal Drawdown and Yield Estimation Problem

- (1) Refer to 650.1205O, “Testing”
- (2) The water stands 75 feet in a well and the pumping test yielded 1,470 gallons per minute with a drawdown of 23 feet. This is 31 percent of the total possible draw down. Figure 12-32 shows that at 31 percent of the maximum drawdown, this nonartesian well will produce 53 percent of the maximum yield, so the maximum yield would be about

$$\frac{1,470}{0.53} = 2,770 \text{ gal/min}$$

- (3) Figure 12-32 shows that 77 percent of the maximum yield can be obtained with a 51-percent (38 ft) drawdown, for a yield of about 2,130 gallons per minute. Use the following test procedures:
- (i) Measure and record the depth to static water level (measure with a steel tape that has 1 to 2 feet. of its lower end chalked).
 - (ii) Determine whether the well is artesian or nonartesian by referring to the well log for evidence of the presence of a confining layer. If the static water level is above the bottom of the confining layer, the well is artesian.
 - (iii) Measure the height of the static water column or 100 percent drawdown. For nonartesian wells, 100 percent drawdown is the depth from the static water level to the bottom of the aquifer or to the bottom of the well if the aquifer is not completely penetrated. For artesian wells, 100 percent drawdown is the depth from static water level or piezometric surface to the bottom of the confining layer.
 - (iv) Pump the well at a near-maximum rate (50% drawdown or slightly more) until drawdown and yield are constant at that rate. When three measurements taken 1 hour apart are the same, drawdown is constant. Measure water levels during pumping with an electric sounder or air line. This may take several hours to several days of continuous pumping. Record drawdown and yield.
 - (v) Convert measured drawdown to percent drawdown. Refer to the above figure to estimate optimum drawdown and yield and the most economical water yield from a specific well.